

MDrive 34ac Hybrid
Step • Torque • Speed
Product manual
V1.00, 07.2012

MDrive 34ac Hybrid Step • Torque • Speed Manual		
Date	Revision	Changes
11/22/2011	V1.00, 07.2012	Format change to reflect current branding and standards. Added support for Hard Stop Tolerant calibration method.

The information in Schneider Electric Motion USA product documentation and on this web site has been carefully checked and is believed to be accurate; however, no responsibility is assumed for inaccuracies.

Schneider Electric Motion USA reserves the right to make changes without further notice to any products to improve reliability, function or design. Schneider Electric Motion USA does not assume any liability arising out of the application or use of any product or circuit described; neither does it convey any license under its patent rights of others.

Schneider Electric Motion USA's general policy does not recommend the use of its products in life support or aircraft applications wherein a failure or malfunction of the product may directly threaten life or injury. Per the terms and conditions of sales of Schneider Electric Motion USA, the user of Schneider Electric Motion USA products in life support or aircraft applications assumes all risks of such use and indemnifies Schneider Electric Motion USA against all damages. aircraft applications assumes all risks of such use and indemnifies Schneider Electric Motion USA against all damages.

Important information

This manual is part of the product.

Carefully read this manual and observe all instructions.

Keep this manual for future reference.

Hand this manual and all other pertinent product documentation over to all users of the product.

Carefully read and observe all safety instructions and the chapter "Before you begin - safety information".

Some products are not available in all countries.

For information on the availability of products, please consult the catalog.

Subject to technical modifications without notice.

All details provided are technical data which do not constitute warranted qualities.

Most of the product designations are registered trademarks of their respective owners, even if this is not explicitly indicated.

This page intentionally left blank

Table of Contents

	Important information	3
	Writing conventions and symbols	1
1	Introduction.....	3
	1.1 About this manual.....	3
	1.2 Unit overview.....	3
	1.3 Components and interfaces	4
	1.3.1 Components	4
	1.3.2 Interfaces.....	5
	1.4 Name plate.....	6
	1.5 Part number identification.....	7
	1.6 Documentation and literature references	7
2	Before you begin - safety information.....	9
	2.1 Qualification of personnel.....	9
	2.2 Intended use.....	9
	2.3 Hazard categories	10
	2.4 Basic information.....	11
	2.5 Standards and terminology	13
3	Technical data.....	15
	3.1 Certifications.....	15
	3.2 Environmental conditions	15
	3.3 Mechanical data	16
	3.3.1 Degree of protection	16
	3.3.2 Mounting position.....	17
	3.3.3 Dimensions (rotary motor)	18
	3.4 Electrical data.....	19
	3.4.1 I/O signals at P1	19
	3.4.2 Communication interface at P2.....	21
	3.4.3 Supply voltage V_{AC} at P3	21
	3.4.4 Encoder outputs at P1	22
	3.5 Motor data	22
	3.5.1 Specifications.....	22
	3.5.2 Performance curves.....	23
4	Basics.....	25
	4.1 Functional safety	25
	4.1.1 Working with IEC 61508	25
5	Engineering.....	27
	5.1 Monitoring functions	28
6	Installation.....	29
	6.1 Electromagnetic compatibility, EMC.....	30
	6.2 Mechanical installation	31
	6.3 Electrical installation.....	34
	6.3.1 Overview of all connectors.....	35
	6.3.2 Connection of the supply voltage V_{AC}	35
	6.3.3 Connection of the I/O interface	37
	6.3.4 Connection of the communication interface.....	41
	6.4 Checking wiring.....	44

7	Commissioning	45
7.1	Preparing for commissioning.....	47
7.1.1	Hybrid Configuration Utility manual	47
8	Operation	49
8.1	Basics.....	49
8.1.1	Overview.....	49
8.1.2	Hybrid motion technology (HMT).....	50
8.1.2	Overview of motor phase current.....	52
8.2	Functions by mode	53
8.2.1	Pulse/direction input mode	53
8.2.2	Torque mode	56
8.2.3	Speed control mode.....	59
8.2.4	Constant velocity mode	62
8.3	Attention output	64
9	Diagnostics and troubleshooting	65
9.1	Error indication and troubleshooting.....	65
9.1.1	Operation state and error indication	65
9.2	Error codes.....	66
10	Accessories and spare parts	67
10.1	Accessories	67
11	Service, maintenance and disposal	69
11.1	Service address.....	70
11.2	Maintenance.....	70
11.3	Replacing units.....	70
11.4	Shipping, storage, disposal	71
12	Glossary	73
12.1	Units and conversion tables	73
12.1.1	Length.....	73
12.1.2	Mass	73
12.1.3	Force.....	73
12.1.4	Power.....	74
12.1.5	Rotation	74
12.1.6	Torque	74
12.1.7	Moment of inertia	74
12.1.8	Temperature	74
12.1.9	Conductor cross section	75
12.2	Terms and Abbreviations	75

List of Figures

Figure 1.1: Components and Interfaces.....	4
Figure 1.3: Part numbering	7
Figure 3.1: Mounting positions	17
Figure 3.2: MDrive 34ac Hybrid dimensions [inches (mm)]	18
Figure 3.5: Overview of connectors	19
Figure 3.6: Speed torque curves.....	23
Figure 6.1: Overview of connectors	35
Figure 6.2: Pin Assignment supply voltage	36
Figure 6.3 Multifunction interface pin assignments	37
Figure 6.5: Line driven input (sourcing).....	39
Figure 6.6: Open collector sinking.....	39
Figure 6.7: Open collector sourcing	39
Figure 6.8: ATTENTION signal output	39
Figure 6.9: ANALOG_IN signal input	40
Figure 6.10: Encoder interface	40
Figure 6.11: Communications interface pin assignments	41
Figure 6.12: Full duplex interface, single mode (RS422).....	43
Figure 6.13: Half-duplex interface, single mode (RS-422/485)...	43
Figure 6.15: Full-duplex interface, party mode (RS422)	43
Figure 8.1: Control bounds for hybrid motion technology	51
Figure 8.2: Overview of motor phase current.....	52
Figure 8.3: Step/direction mode block diagram.....	53
Figure 8.4: Pulse/direction signals and timing.....	54
Figure 8.5: A/B (quadrature) encoder signals	54
Figure 8.6: CW/CCW (clock up/down) input signals	55
Figure 8.7: Torque mode block diagram showing sinking input interface	56
Figure 8.8: Analog settings for torque mode	57
Figure 8.9: Speed control mode block diagram showing sinking input interface.....	59
Figure 8.10: Analog settings for speed control mode.....	60
Figure 8.11: Speed control mode block diagram showing sinking input interface.....	62

Writing conventions and symbols



Work steps If work steps must be performed consecutively, this sequence of steps is represented as follows:

- Special prerequisites for the following work steps
- ▶ Step 1
- ◁ Specific response to this work step
- ▶ Step 2

If a response to a work step is indicated, this allows you to verify that the work step has been performed correctly.

Unless otherwise stated, the individual steps must be performed in the specified sequence.

Bulleted lists The items in bulleted lists are sorted alphanumerically or by priority. Bulleted lists are structured as follows:

- Item 1 of bulleted list
- Item 2 of bulleted list
 - Subitem for 2
 - Subitem for 2
- Item 3 of bulleted list

Making work easier Information on making work easier is highlighted by this symbol:



Sections highlighted this way provide supplementary information on making work easier.

Parameters Parameters are shown as follows

RC Motor Run Current

Units of measure Measurements are given US units, metric values are given in SI units in parenthesis.

Examples”

1.00 in (25.4 mm)
100 oz-in (70 N-cm)

Page intentionally left blank

1 Introduction

1

1.1 About this manual

CAUTION

MULTI-MODE OPERATION

This device will operate differently in each mode of operation. It is critical that all documentation be read completely. A clear understanding of how the device is to be employed must be present before attempting to install or commission the device.

Failure to follow these instructions can result in equipment damage.

This manual is valid for all standard products. This chapter lists the type code for this product. The type code can be used to identify whether your product is a standard product or a customized model.

1.2 Unit overview

The “MDrive 34ac Hybrid Step • Torque • Speed” consists of a stepper motor and integrated electronics. The product integrates interfaces, drive and control electronics and the power supply.

Operating modes

The “MDrive 34ac Hybrid Step • Torque • Speed” moves the stepper motor in a fashion dictated by the selected mode:

- **Step/direction mode:** In Step/direction mode the device will move the stepper motor as specified by a reference value. The setpoint signal is generated by a position or stepper controller and fed to the multifunction interface as a pulse signal. Shaft direction is controlled by a logic state on the direction input of the multifunction interface.
- **Torque control mode:** In torque control mode the device will maintain constant torque on the shaft at a value determined by a reference voltage fed to the analog input of the multifunction interface. The pulses are generated via an internal clock generator.
- **Speed control mode:** In speed control mode the device will move the stepper motor at a velocity determined by a reference voltage fed to the analog input of the multifunction interface. The pulses are generated via an internal clock generator.
- **Velocity control mode:** In velocity control mode the device will move the stepper motor at a constant velocity determined by an integer value input via the service interface. The pulses are generated via an internal clock generator.

Step resolution in all modes is set as a parameter via the service interface.

1.3 Components and interfaces

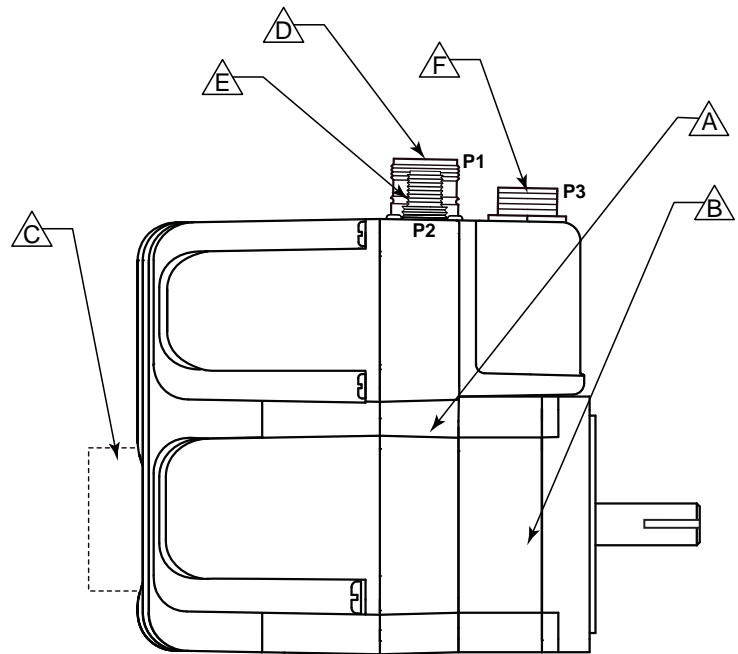

Figure 1.1: Components and Interfaces

- (A) Electronics housing
- (B) Two phase stepper motor
- (C) Control knob option
- (D) I/O and encoder connector (P1)
- (E) RS422/485 communication (P2)
- (F) AC power input (P3)

1.3.1 Components

Motor The motor is a two phase brushless stepper motor. The motor has a high torque density due to the use of the latest magnetic materials and enhanced design. The step angle of the motor is 1.8°.

Electronics housing The electronics system is comprised of a 120 or 240 VAC power supply, control electronics and driver. The drive system is controlled by external reference signals via the communication and I/O interface.

1.3.2 Interfaces

Standard available interfaces.

I/O and encoder interface

The multifunction interface operates at the following signal levels:

- Logic signals are opto-isolated
- The Attention output is opto-isolated
- 0 to 10V analog signal is not isolated
- 5V differential encoder signals are not isolated

The reference pulses are supplied via two of the inputs, either as pulse/direction signals, AB signals or quadrature signals. The other 24V input functions as “power stage enable”. An “opto-reference” input is used to define the inputs as sinking or sourcing.

A 24V output signal is used indicating a condition or conditions. These conditions are selected during parameterization.

In speed or torque mode, a 0 to 5V or -10 to 10V reference voltage is applied to the analog input to determine the velocity of the shaft or the percentage of motor torque applied to the load.

The 5V differential signals function as an encoder output interface.

Communication interface

The service interface provides a connection to the communication bus.

A PC may be connected to the interface via a USB to RS422 converter. The commissioning software may then be used for tasks such as parameterization and monitoring the status of the device.

The communication interface is also used for firmware upgrades.

AC power input

Connects to the system AC power line.



The ground connections of all interfaces are galvanically connected. For more information see chapter 5.2 “Ground design”. This chapter also provides information on protection against reverse polarity.

1.4 Name plate

The name plate has the following information

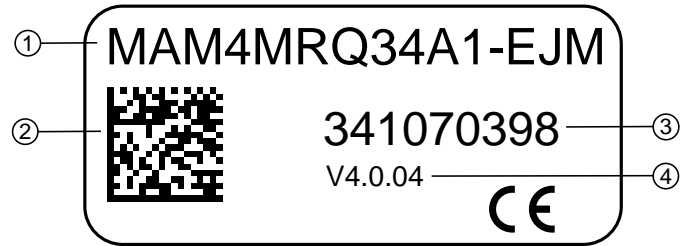

Figure 1.2: Name plate

- (1) Part number
- (2) Datamatrix containing all pertinent information about the device
- (3) Serial number
- (4) Firmware revision

1.5 Part number identification

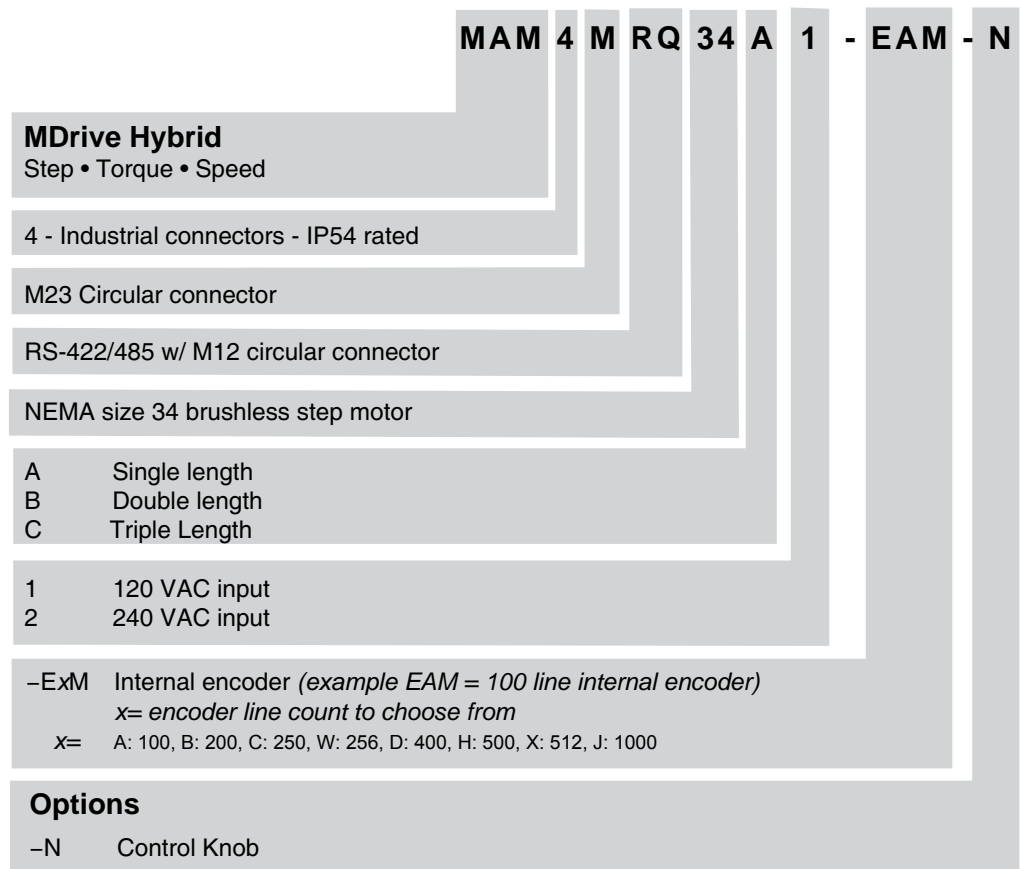

Figure 1.3: Part numbering

1.6 Documentation and literature references

This document must be used in conjunction with the Hybrid Configurator Utility software manual. The Hybrid Configurator Utility is the software tool used to commission and parameterize the MDrive 34ac Hybrid Step • Torque • Speed.

Source product manuals The current product manuals are available for download from the Internet.

<http://motion.schneider-electric.com>

This page intentionally left blank

2 Before you begin - safety information

2

The information provided in this manual supplements the product manual. Carefully read the product manual before using the product.

2.1 Qualification of personnel

Only appropriately trained persons who are familiar with and understand the contents of this manual and all other pertinent product documentation are authorized to work on and with this product. In addition, these persons must have received safety training to recognize and avoid hazards involved. These persons must have sufficient technical training, knowledge and experience and be able to foresee and detect potential hazards that may be caused by using the product, by changing the settings and by the mechanical, electrical and electronic equipment of the entire system in which the product is used.

All persons working on and with the product must be fully familiar with all applicable standards, directives, and accident prevention regulations when performing such work.

2.2 Intended use

The functions described in this manual are only intended for use with the basic product; you must read and understand the appropriate product manual.

The product may only be used in compliance with all applicable safety regulations and directives, the specified requirements and the technical data.

Prior to using the product, you must perform a risk assessment in view of the planned application. Based on the results, the appropriate safety measures must be implemented.

Since the product is used as a component in an entire system, you must ensure the safety of persons by means of the design of this entire system (for example, machine design).

Operate the product only with the specified cables and accessories. Use only genuine accessories and spare parts.

Any use other than the use explicitly permitted is prohibited and can result in hazards.

Electrical equipment should be installed, operated, serviced, and maintained only by qualified personnel.

The product must NEVER be operated in explosive atmospheres (hazardous locations, Ex areas).

2.3 Hazard categories

Safety instructions to the user are highlighted by safety alert symbols in the manual. In addition, labels with symbols and/or instructions are attached to the product that alert you to potential hazards.

Depending on the seriousness of the hazard, the safety instructions are divided into 4 hazard categories.

▲ DANGER

DANGER indicates an imminently hazardous situation, which, if not avoided, will result in death or serious injury.

▲ WARNING

WARNING indicates a potentially hazardous situation, which, if not avoided, **can result** in death, serious injury, or equipment damage.

▲ CAUTION

CAUTION indicates a potentially hazardous situation, which, if not avoided, **can result** in injury or equipment damage.

CAUTION

CAUTION used without the safety alert symbol, is used to address practices not related to personal injury (e.g. **can result** in equipment damage).

2.4 Basic information

▲ DANGER

UNINTENDED CONSEQUENCES OF EQUIPMENT OPERATION

When the system is started, the drives are usually out of the operator's view and cannot be visually monitored.

- Only start the system if there are no persons in the hazardous area.

Failure to follow these instructions will result in death or serious injury.

▲ WARNING

UNEXPECTED MOVEMENT

Drives may perform unexpected movements because of incorrect wiring, incorrect settings, incorrect data or other errors.

Interference (EMC) may cause unpredictable responses in the system.

- Carefully install the wiring in accordance with the EMC requirements.
- Ensure the BRIDGE ENABLE input is inactive to avoid an unexpected restart of the motor before switching on and configuring the drive system.
- Do NOT operate the drive system with unknown settings or data.
- Perform a comprehensive commissioning test.

Failure to follow these instructions can result in death or serious injury.

▲ WARNING**LOSS OF CONTROL**

- The designer of any control scheme must consider the potential failure modes of control paths and, for certain critical functions, provide a means to achieve a safe state during and after a path failure. Examples of critical control functions are emergency stop, overtravel stop, power outage and restart.
- Separate or redundant control paths must be provided for critical functions.
- System control paths may include communication links. Consideration must be given to the implication of unanticipated transmission delays or failures of the link.
- Observe all accident prevention regulations and local safety guidelines. 1)
- Each implementation of the product must be individually and thoroughly tested for proper operation before being placed into service.

Failure to follow these instructions can result in death or serious injury.

1) For USA: Additional information, refer to NEMA ICS 1.1 (latest edition), "Safety Guidelines for the Application, Installation, and Maintenance of Solid State Control" and to NEMA ICS 7.1 (latest edition), "Safety Standards for Construction and Guide for Selection, Installation and Operation of Adjustable-Speed Drive Systems".

▲ CAUTION**UNEXPECTED BEHAVIOR AND DESTRUCTION OF SYSTEM COMPONENTS**

When you work on the wiring and when you unplug or plug in connectors, this may cause unexpected behavior and destruction of system components.

- Switch the power supply off before working on the wiring.

Failure to follow these instructions can result in injury or equipment damage.

▲ CAUTION**MOVEMENT ON POWER APPLICATION**

Hybrid Motion Technology's functionality requires that the rotor and stator of the motor be in precise alignment. To accomplish this, the product will perform an initial calibration move upon power up consisting of a 6 motor full step (10.8°) move in the clockwise direction, followed by a 3 motor full step (5.4°) move in the counter-clockwise direction.

- Only power the system if there are no persons in the hazardous area.

Failure to follow these instructions can result in injury or equipment damage.

2.5 Standards and terminology

Technical terms, terminology and the corresponding descriptions in this manual are intended to use the terms or definitions of the pertinent standards.

In the area of drive systems, this includes, but is not limited to, terms such as “safety function”, “safe state”, “fault”, “fault reset”, “failure”, “error”, “error message”, “warning”, “warning message”, etc.

Among others, these standards include:

- IEC 61800 series: “Adjustable speed electrical power drive systems”
- IEC 61800-7 series: “Adjustable speed electrical power drive systems - Part 7-1: Generic interface and use of profiles for power drive systems - Interface definition”
- IEC 61158 series: “Industrial communication networks - Field-bus specifications”
- IEC 61784 series: “Industrial communication networks - Profiles”
- IEC 61508 series: “Functional safety of electrical/electronic/programmable electronic safety-related systems”

This page intentionally left blank

3 Technical data

3

This chapter contains information on the ambient conditions and on the mechanical and electrical properties of the device family and the accessories.

3.1 Certifications

Product certifications:

Certified by	Assigned number	Validity
CE	—	6/15/2009
UL508C	NMMS2.E302833	

3.2 Environmental conditions

Ambient operating conditions

The maximum permissible ambient temperature during operation depends on the distance between the devices and the required power. Observe the pertinent instructions in the chapter Installation.

The following relative humidity is permissible during operation.

Operating temperature ¹⁾	[°C]	-20 ... 50 (no icing)
Temperature variation	[°C/min]	0.5
Humidity	[%]	5 ... 95 (non-condensing)

Ambient conditions: transportation and storage

The environment during transport and storage must be dry and free from dust. The maximum vibration and shock load must be within the specified limits.

Temperature	[°C]	-25 ... 70
Temperature variation	[°C]	-25 ... 30
Humidity	[%]	5 ... 95 (non-condensing)

Maximum operating temperatures

Power stage ¹⁾	[°C]	75
Motor ²⁾	[°C]	90

- 1) May be read via parameter
- 2) Measured on the surface

Installation altitude

The installation altitude is defined as height above sea level

Installation altitude ¹⁾	[ft (m)]	3280 (1000)
-------------------------------------	----------	-------------

- 3) Installation above 3280 (1000) may require derating output current and maximum ambient temperature.

EMC

Emission	EIC61800-3 (Category C2)
Noise immunity	IEC61000-6-2

3.3 Mechanical data

3.3.1 Degree of protection

IP degree of protection

The product has the following IP degree of protection as per EN 60529.

Degree of protection	IP54
----------------------	------

The total degree of protection is determined by the component with the lowest degree of protection.

IP degrees of protection overview

First digit		Second digit	
Protection against intrusion of objects		Protection against intrusion of water	
0	No protection	0	No protection
1	External objects >50 mm	1	Vertically falling dripping water
2	External objects >12 mm	2	Dripping water falling at an angle (75 ° ... 90 °)
3	External objects >2.5 mm	3	Spraying water
4	External objects >1 mm	4	Splashing water
5	Dust-protected	5	Water jets
6	Dust-tight	6	Heavy sea
		7	Immersion
		8	Submersion

3.3.2 Mounting position

The following mounting positions are defined and approved as per EN 60034-7:

- IM B5 drive shaft horizontal
- IM V1 drive shaft vertical, shaft end down
- IM V3 drive shaft vertical, shaft end up

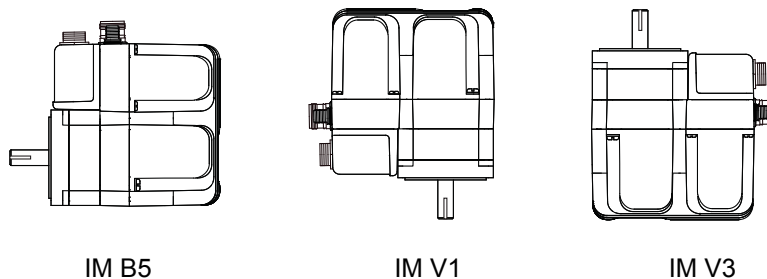

Figure 3.1: Mounting positions

3.3.3 Dimensions (rotary motor)

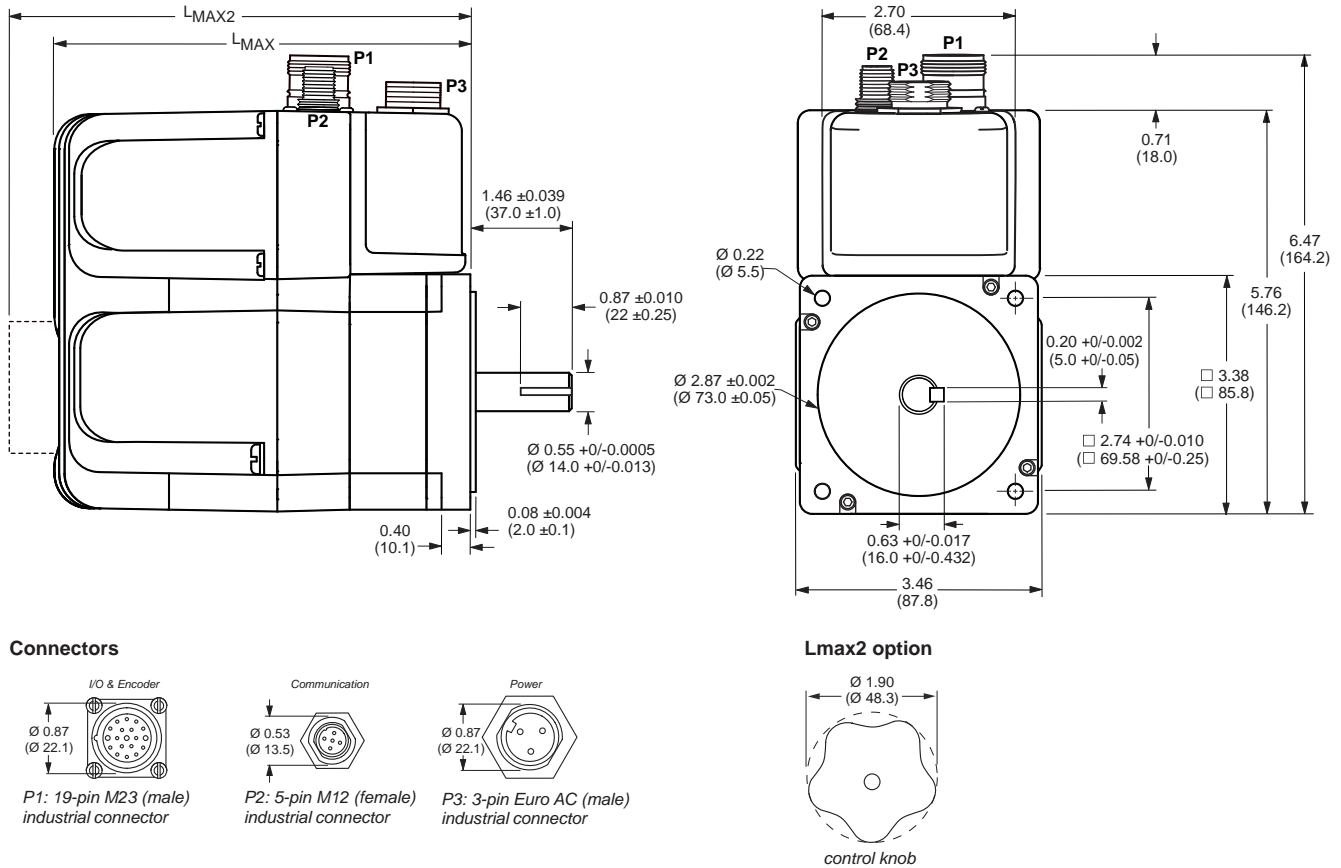

Figure 3.2: MDrive 34ac Hybrid dimensions [inches (mm)]

	L_{MAX1}	L_{MAX2}
Single	6.1 (155.0)	7.1 (180.4)
Double	6.9 (174.3)	7.9 (199.7)
Triple	8.4 (214.3)	9.4 (239.7)

3.4 Electrical data

Overview of connectors

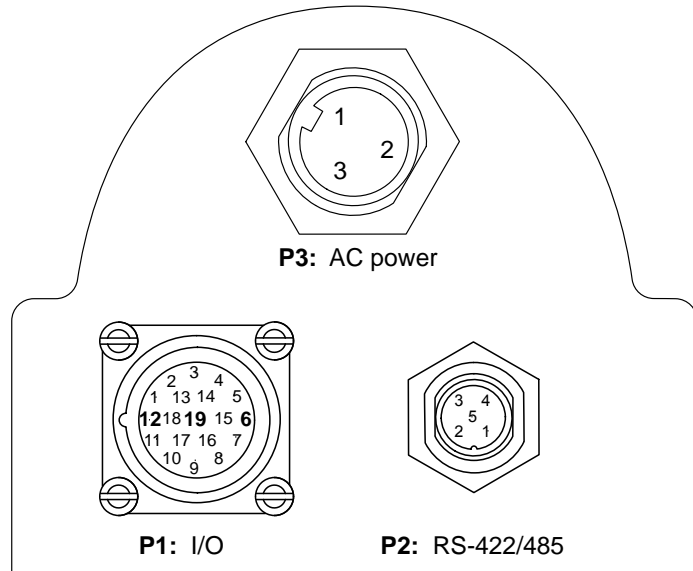

Figure 3.5: Overview of connectors

3.4.1 I/O signals at P1

Signal inputs

The signal input functions include `STEP_MOTION`, `DIRECTION`, and `BRIDGE_ENABLE`. They may be used as sinking or sourcing based upon the bias of the `OPTO_REFERENCE`

Voltage range	[+V _{dc}]	5 ... 24
input current (5V)	[mA]	8.7
Input current (24V)	[mA]	14.6
Input frequency		
Pulse (step) configuration	[MHz]	5
Quadrature configuration	[MHz]	1.25
Motion configuration, enable	[kHz]	5
Isolation		Galvanic
Protection class		III

<i>Analog input</i>		
Voltage mode 0 - 5	[V _{dc}]	0 ... 5
Voltage mode 0 - 10	[V _{dc}]	0 ... 10
Voltage mode -10/+10	[V _{dc}]	-10 ... 10
Resolution	[Bits]	10
Impedance by mode		
0 - 5 V	[MΩ]	5
0 - 10 V	[kΩ]	1.25
0 - 20 mA	[Ω]	5
Isolation		None

Signal outputs The ATTENTION_OUTPUT may be configured as open-collector or open-emitter based upon connection method

Voltage open-collector	[V _{dc}]	60
Voltage open-emitter	[V _{dc}]	7
Current open-collector	[mA]	
Current open-emitter	[mA]	5.5
Isolation		Galvanic

3.4.2 Communication interface at P2

RS422/485 RS422/485 serial communications bus. Interface can be half-duplex (2 wire RS-422/485) or full-duplex (4 wire RS-422). Multi-drop addressable to 62 nodes.

Characteristic of serial data lines		RS422/485
Baud rate	[kbps]	4.8 ... 115
Isolation		Galvanic

3.4.3 Supply voltage v_{AC} at P3

▲ CAUTION

MOVEMENT ON POWER APPLICATION

Hybrid Motion Technology’s functionality requires that the rotor and stator of the motor be in precise alignment. To accomplish this, the product will perform an initial calibration move upon power up consisting of a 6 motor full step (10.8°) move in the clockwise direction, followed by a 3 motor full step (5.4°) move in the counter-clockwise direction.

- Only power the system if there are no persons in the hazardous area.

Failure to follow these instructions can result in injury or equipment damage.

		MDrive 34ac Hybrid
Limit values min/max ¹⁾	[+V _{ac}] (120 VAC model)	95 to 132 VAC @ 50/60 Hz
	[+V _{ac}] (1240 VAC model)	95 to 264 VAC @ 50/60 Hz
Continuous. current input	[A] (120 VAC)	0.8
	[A] (240 VAC)	0.4
Peak instantaneous current	[A] (120 VAC)	4.2
	[A] (240 VAC)	2.1

1) See chapter 5.1.1 “Supply voltage”

UL Conditions of acceptability

When used in end-product equipment, the following are among the considerations to be made:

- 1) The temperature tests were conducted with the device's face mounted to an aluminum heat sink. For devices with the frame designation 34, the dimensions for the heat sink were 10" x 10" x 1/4". The shaft was also provided with aluminum wheels, approximately 4" in diameter and 1/4" thick.
- 2) These devices are intended for installation in a Pollution Degree 2 (controlled) environment. Suitability of the spacings shall be considered in end use application.
- 3) The enclosure of this device is intended as the final end use enclosure.
- 4) These devices do not provide motor overload protection, or motor over-temperature protection. The need for motor overload protection and/or over-temperature protection shall be determined in the end product.
- 5) Based on ratings less than 1 hp and no provisions for motor overload protection, these devices have not been subjected to the short circuit test. This test shall be considered in the end-product investigation.

3.4.4 Encoder outputs at P1

Output characteristic		RS422
Channel frequency	[MHz]	1.25
Phase shift A->B, B->A	[ns]	800
Cycle duration	[ns]	400
Pulse duration	[ns]	200
Input-output delay	[ns]	125
Isolation		None

3.5 Motor data

3.5.1 Specifications

		Single	Double	Triple
Holding torque	oz-in (N-cm)	330.0 (233.0)	500.0 (353.0)	750.0 (529.0)
Detent torque	oz-in (N-cm)	10.9 (7.7)	14.16 (10.0)	19.83 (14.0)
Rotor inertia	oz-in-sec ² (kg-cm ²)	0.01416 (1.0)	0.02266 (1.6)	0.04815 (3.)
Radial load limit	lbs (kg)	15 (6.8)	15 (6.8)	15 (6.8)
Axial load limit	lbs (kg)	0	0	0
Weight	lb (kg)	6.4 (2.9)	7.7 (3.5)	11 (5.0)

3.5.2 Performance curves

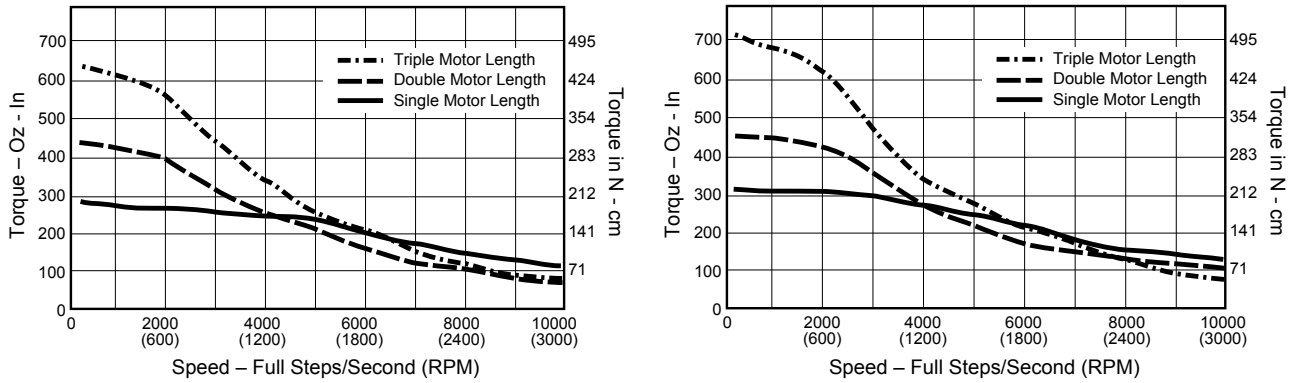

Figure 3.6: Speed torque curves

Page intentionally left blank

4 Basics

4

4.1 Functional safety

Automation and safety engineering are two areas that were completely separated in the past but recently have become more and more integrated.

Engineering and installation of complex automation solutions are greatly simplified by integrated safety functions.

Usually, the safety engineering requirements depend on the application. The level of the requirements results from the risk and the hazard potential arising from the specific application.

4.1.1 Working with IEC 61508

IEC 61508 standard

The standard IEC 61508 “Functional safety of electrical/electronic/programmable electronic safety-related systems” covers the safety-related function. It is not only one single component but the entire function chain (e.g. from the sensor through the logical processing unit to the actuator) that is considered as one single unit. This function chain must meet the requirements of the specific safety integrity level as a whole. Systems and components that can be used in various applications for safety tasks with comparable risk levels can be developed on this basis.

SIL, Safety Integrity Level

The standard IEC 61508 defines 4 safety integrity levels (SIL) for safety functions. SIL1 is the lowest level and SIL4 is the highest level. A hazard and risk analysis serves as a basis for determining the required safety integrity level. This is used to decide whether the relevant function chain is to be considered as a safety function and which hazard potential it must cover.

PFH, Probability of a dangerous hardware failure per hour

To maintain the safety function, the IEC 61508 standard requires various levels of measures for avoiding and controlling faults, depending on the required SIL. All components of a safety function must be subjected to a probability assessment to evaluate the effectiveness of the measures implemented for controlling faults. This assessment determines the PFH (probability of a dangerous failure per hour) for a safety system. This is the probability per hour that a safety system fails in a hazardous manner and the safety function cannot be correctly executed. Depending on the SIL, the PFH must not exceed certain values for the entire safety system. The individual PFH values of a function chain are added; the total PFH value must not exceed the maximum value specified in the standard.

Page intentionally left blank

5 Engineering

5

This chapter contains information on the application of the product that is vital in the design phase.

CAUTION

MULTI-MODE OPERATION

This device will operate differently in each mode of operation. It is critical that all documentation be read completely. A clear understanding of how the device is to be employed must be present before attempting to install or commission the device.

Failure to follow these instructions can result in equipment damage.

▲ CAUTION

MOVEMENT ON POWER APPLICATION

Hybrid Motion Technology's functionality requires that the rotor and stator of the motor be in precise alignment. To accomplish this, the product will perform an initial calibration move upon power up consisting of a 6 motor full step (10.8°) move in the clockwise direction, followed by a 3 motor full step (5.4°) move in the counter-clockwise direction.

- Only power the system if there are no persons in the hazardous area.

Failure to follow these instructions can result in injury or equipment damage.

5.1 Monitoring functions

The monitoring functions in the product can help to guard the system and reduce the risks involved in a system malfunction. These monitoring functions may not be used to protect persons.

The following monitoring functions are available and be monitored by two methods:

- 1) **Software:** may be monitored using software via the communication interface
- 2) **Hardware:** may be monitored using the `ATTENTION_OUTPUT` via the multifunction interface.

Monitoring	Task
Error	Software error
Locked rotor	Monitors for locked rotor condition
HMT active	Monitors the active/inactive state of Hybrid Motion Technology
Over Temperature	Monitors for over temperature condition
Fault	Monitors for a fault condition

6 Installation

6

▲ WARNING

LOSS OF CONTROL

- The designer of any control scheme must consider the potential failure modes of control paths and, for certain critical functions, provide a means to achieve a safe state during and after a path failure. Examples of critical control functions are EMERGENCY STOP, overtravel stop, power outage and restart.
- Separate or redundant control paths must be provided for critical functions.
- System control paths may include communication links. Consideration must be given to the implication of unanticipated transmission delays or failures of the link.
- Observe all accident prevention regulations and local safety guidelines. 1)
- Each implementation of the product must be individually and thoroughly tested for proper operation before being placed into service.

Failure to follow these instructions can result in death or serious injury.

1) For USA: Additional information, refer to NEMA ICS 1.1 (latest edition), "Safety Guidelines for the Application, Installation, and Maintenance of Solid State Control" and to NEMA ICS 7.1 (latest edition), "Safety Standards for Construction and Guide for Selection, Installation and Operation of Adjustable-Speed Drive Systems".

▲ CAUTION

RISK OF INJURY WHEN REMOVING CIRCUIT BOARD PLUGS

- When removing them note that the connectors must be unlocked.
 - Supply voltage VDC: Unlock by pulling at the plug housing
 - Miscellaneous: Unlock by pressing the locking lever
- Always hold the plug to remove it (not the cable).

Failure to follow these instructions can result in injury or equipment damage.



Chapter 5, Engineering, contains basic information that you should now before starting the installation.

6.1 Electromagnetic compatibility, EMC

▲ WARNING
SIGNAL AND DEVICE INTERFERENCE
Signal interference can cause unexpected responses of device.
<ul style="list-style-type: none"> • Install the wiring in accordance with the EMC requirements. • Verify compliance with the EMC requirements.
Failure to follow these instructions can result in death or serious injury.

This drive system meets the EMC requirements according to the standard IEC 61800-3, if the described measures are implemented during installation. If it is operated outside this scope, note the following:

▲ WARNING
HIGH-FREQUENCY INTERFERENCE
<ul style="list-style-type: none"> • In a domestic environment this product may cause high-frequency interference that may require action to suppress interference.
Failure to follow these instructions can result in death or serious injury.

EMC measures	Effect
Keep cables as short as possible. Do not install unnecessary cable loops, use short cables from the star point in the control cabinet to the external ground connection.	Reduces capacitive and inductive interference.
Ground the product via the motor flange or with a ground strap to the ground connection at the cover of the connector housing.	Reduces emissions, increases immunity.
Ground shields of digital signal wires at both ends by connecting them to a large surface or via conductive connector housings.	Reduces interference affecting the signal wires, reduces emissions
Connect large surface areas of cable shields, use cable clamps and ground straps	Reduces emissions.

The following cables must be shielded:

- Communications interface
- I/O interface

Equipotential bonding conductors

Potential differences can result in excessive currents on the cable shields. Use equipotential bonding conductors to reduce currents on the cable shields. The equipotential bonding conductor must be rated for the maximum current flowing. Practical experience has shown that the following conductor cross sections can be used:

- AWG 4 (16 mm²) for equipotential bonding conductors up to a length of 650 ft (200 m)
- AWG 4 (20 mm²) for equipotential bonding conductors with a length of more than 650 ft (200 m)

6.2 Mechanical installation

▲ CAUTION
<p>HOT SURFACES</p> <p>Depending on the operation, the surface may heat up to more than 90°C (194°F).</p> <ul style="list-style-type: none"> ● Do not allow contact with the hot surfaces. ● Do not allow flammable or heat-sensitive parts in the immediate vicinity. ● Consider the measures for heat dissipation described. ● Check the temperature during test runs. <p>Failure to follow these instructions can result in injury or equipment damage.</p>

▲ CAUTION
<p>MOTOR DAMAGE AND LOSS OF CONTROL</p> <p>Shock or strong pressure applied to the motor shaft may destroy the motor.</p> <ul style="list-style-type: none"> ● Protect the motor shaft during handling and transportation. ● Avoid shocks to the motor shaft during mounting. ● Do not press parts onto the shaft. Mount parts to the shaft by glueing, clamping, shrink-fitting or screwing. <p>Failure to follow these instructions can result in injury or equipment damage.</p>

▲ CAUTION
<p>MOVEMENT ON POWER APPLICATION</p> <p>Hybrid Motion Technology's functionality requires that the rotor and stator of the motor be in precise alignment. To accomplish this, the product will perform an initial calibration move upon power up consisting of a 6 motor full step (10.8°) move in the clockwise direction, followed by a 3 motor full step (5.4°) move in the counter-clockwise direction.</p> <ul style="list-style-type: none"> • Only power the system if there are no persons in the hazardous area. <p>Failure to follow these instructions can result in injury or equipment damage.</p>

V1.00, 07.2012

▲ WARNING**MOTOR WITHOUT BRAKING EFFECT**

If power outage and faults cause the power stage to be switched off, the motor is no longer stopped by the brake and may increase its speed even more until it reaches a mechanical stop.

- Verify the mechanical situation.
- If necessary, use a cushioned mechanical stop or a suitable brake.

Failure to follow these instructions can result in death or serious injury.

▲ WARNING**LOSS OF BRAKING FORCE DUE TO WEAR OR HIGH TEMPERATURE**

Applying the holding brake while the motor is running will cause excessive wear and loss of the braking force. Heat decreases the braking force.

- Do not use the brake as a service brake.
- Note that “EMERGENCY STOPS” may also cause wear
- At operating temperatures of more than 80°C (176°F), do not exceed a maximum of 50% of the specified holding torque when using the brake.

Failure to follow these instructions can result in death or serious injury.

▲ WARNING**LOAD FALLS DURING SWITCHING ON**

When the brake of stepping motor drives is released and external forces are applied (vertical axes), the load may fall if the friction is low.

- In such applications, limit the load to a maximum of 25% of the static holding torque.

Failure to follow these instructions can result in death or serious injury.



To install a drive in locations difficult to access, it may be useful to carry out the electrical installation first and then install the fully wired drive.

- Heat dissipation* The motor may become very hot, e.g. in the case of incorrect arrangement of multiple motor. The surface temperature of the motor must not exceed 90 °C during continuous operation.
- Verify that the maximum temperature is not exceeded.
 - Verify that there is sufficient heat dissipation, e.g. by means of good ventilation or heat dissipation via the motor flange.
- Mounting* The motor is designed to be mounted using four screws. The motor flange must be mounted on a flat surface to avoid mechanical tension from being transmitted to the housing. Painted surfaces have an insulating effect. During mounting verify that the motor flange is mounted in such a way as to allow for good conductivity (electrical and thermal).
- Mounting screw sizes [standard (metric)]
- #10 (M5)
- Mounting distances* No minimum clearances are required for installation. However, note that the motor can become very hot. Observe the bending radii of the cables used.
- Ambient conditions* Observe the permissible ambient conditions.

6.3 Electrical installation

▲ CAUTION

DAMAGE TO SYSTEM COMPONENTS AND LOSS OF CONTROL

Interruptions of the negative connection of the controller supply voltage can cause excessively high voltages at the signal connections.

- Do not interrupt the negative connection between the power supply unit and load with a fuse or switch.
- Verify correct connection before switching on.
- Do not connect the controller supply voltage or change its wiring while the is supply voltage present..

Failure to follow these instructions can result in injury or equipment damage.

CAUTION

MULTI-MODE OPERATION

This device will operate differently in each mode of operation. It is critical that all documentation be read completely. A clear understanding of how the device is to be employed must be present before attempting to install or commission the device.

Failure to follow these instructions can result in equipment damage.

CAUTION

RECIRCULATING CURRENTS

Connecting RS422/485 communication in multi-drop system can result in unwanted recirculating currents (ground loops) in the system.

These can be eliminated by grounding the communication port of the first system device. Leave the communication ground of subsequent devices floating.

Failure to follow these instructions can result in equipment damage.



Chapter 5, Engineering, contains basic information that you should now before starting the installation.

6.3.1 Overview of all connectors

Overview of connectors

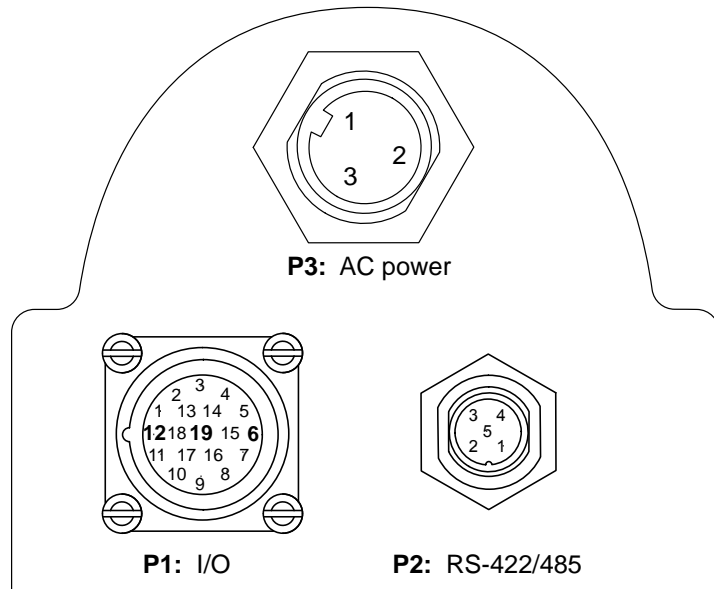

Figure 6.1: Overview of connectors

Connector	Assignment
P1	I/O and encoder interface
P2	Communication interface
P3	Power interface

6.3.2 Connection of the supply voltage V_{AC}

▲ CAUTION
<p>DAMAGE TO SYSTEM COMPONENTS AND LOSS OF CONTROL</p> <p>Interruptions of the negative connection of the controller supply voltage can cause excessively high voltages at the signal connections.</p> <ul style="list-style-type: none"> • Do not interrupt the negative connection between the power supply unit and load with a fuse or switch. • Verify correct connection before switching on. • Do not connect the controller supply voltage or change its wiring while the is supply voltage present.. <p>Failure to follow these instructions can result in injury or equipment damage.</p>

Pin assignment

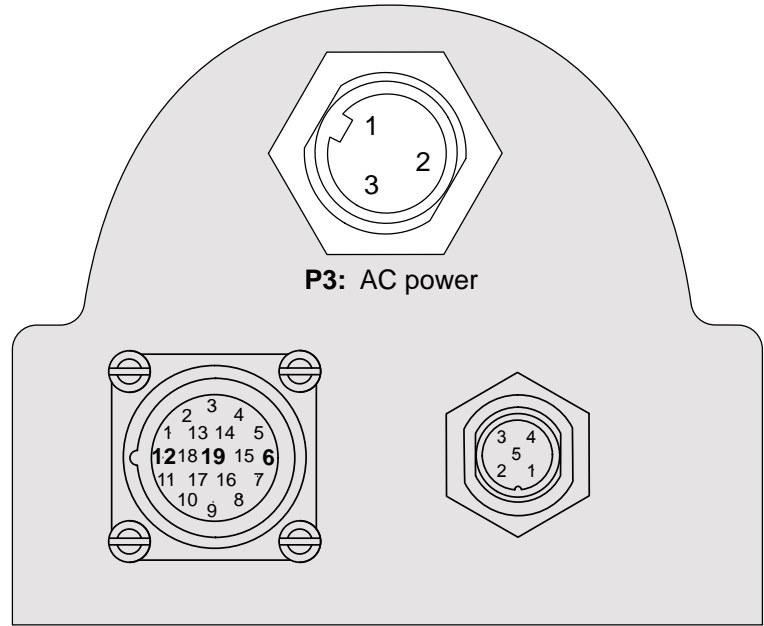

Figure 6.2: Pin Assignment supply voltage

Signal	Function	Pin number	Cable option wire color
EARTH	AC earth connection	1	Green/yelloy
LINE	AC line connection	2	Brown
NEUTRAL	CA neutral connection	3	Blue

Wiring/cable specifications

- Use of the MD-CS200-000 or MD-CS201-000 or equivalent is required in order to meet UL conditions of acceptability.

A connector kit is not available for this connector. The recommended mating connector is:

Field attachable mate Lumberg RKC 30/11

Cable Ø 8 to 10 mm 3-wire AC cord

6.3.3 Connection of the I/O interface

Pin assignments

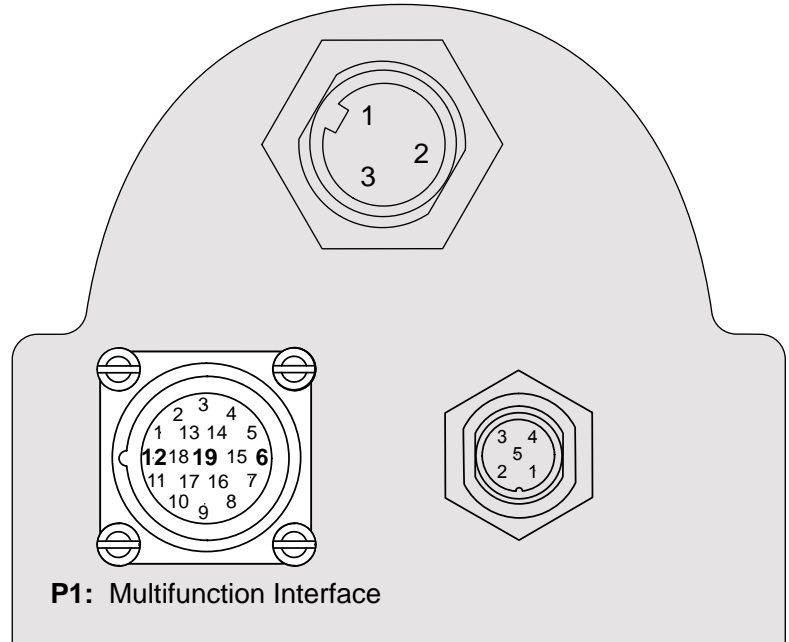

Figure 6.3 Multifunction interface pin assignments

Pin	Signal	Function	Cable option wire color
1	OPTO_REF	Biases the input as sinking or sourcing	Violet
2	ENABLE	Enable/disable the power stage	Red
3	INDEX+	Index mark positive output	Gray
4	CH B+	Channel B positive output	Red/Blue stripe
5	CH B-	Channel B negative output	Green
6	N/C	Not connected	Blue
7	CH A+	Channel A positive output	Gray/Pink stripe
8	ATTN_OUT_C	Minus (collector) output of the attention output	White/Green stripe
9	AUX_POWER	The AUX power input will keep the micro powered in the absence of motor power.	White/Yellow stripe
10	ANALOG+5V	+5 VDC output (10kΩ pot +).	White/Gray strip
11	ANALOG_GND	Analog input ground (10kΩ pot -).	Black
12	Shell	Shell Connect	Green/Yellow stripe

Pin	Signal	Function	Cable option wire color
13	DIRECTION	CW/CCW direction input	Yellow/Brown stripe
14	INDEX-	Index mark negative output	Brown/Green stripe
15	CH A-	Channel A negative output	White
16	ANALOG_IN	Analog input used in Torque and Speed modes of operation. Input may be configured to accept the following voltage ranges: 0 to +5V, 0 to +10V or -10 to +10V. If using a 10kΩ pot, the centertap is connected here.	Yellow
17	ATTN_OUT_E	Plus (emitter) output of the attention output	Pink
18	MOTION	Step input for step/direction mode or stop/start for torque, speed and velocity modes	Gray/Brown stripe
19	AUX_GND	Auxiliary supply ground	Brown

Wiring/cable specifications A connector kit is not available for this connector. The recommended mating connector is:

Field attachable mate Straight: Lumberg RKC190/13.5
 Right-angle: Lumberg RKCW190/13.5

Wiring/cable specifications

- Shielded cable
- Twisted-pair cables
- Grounding of the shield at both ends

Max cable length ¹⁾	feet (m)	328 (100)
Minimum conductor cross section	AWG (mm ²)	24 (0,14)
Maximum conductor cross section	AWG (mm ²)	20 (0,6)
Stripping length	inches (mm)	0.25 (6,0)

1) The length depends on the conductor cross section and the driver circuit used

- ▶ Use equipotential bonding conductors.
- ▶ Verify that wiring, cables and connected interfaces meet the PELV requirements.

Circuit of the signal inputs

The signal inputs may be interfaced as sinking or sourcing as determined by the bias of the `OPTO_REFERENCE`. Connecting the `OPTO_REFERENCE` to a 5 ... 24V power source will provide sinking inputs. Connecting it to ground will provide sourcing inputs.

The `ACTIVE LOGIC HIGH/LOW` state of the inputs is set during the commissioning of the device using the MDrive 34ac Hybrid Step • Torque • Speed configuration tool.

The inputs are galvanically isolated by means of optocouplers.

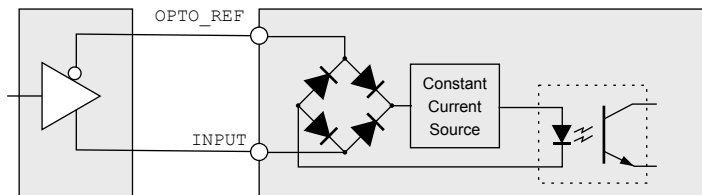

Figure 6.5: Line driven input (sourcing)

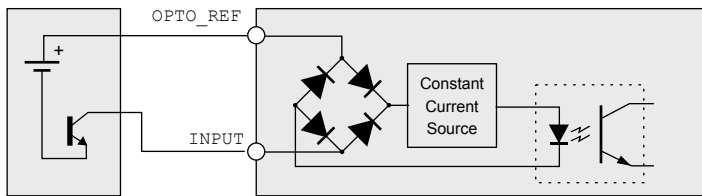

Figure 6.6: Open collector sinking

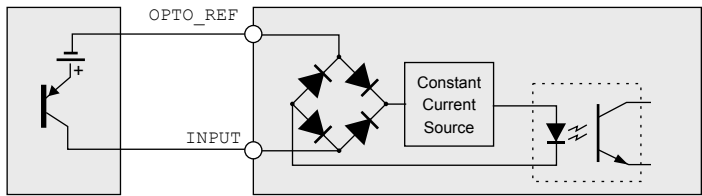

Figure 6.7: Open collector sourcing

Signal output circuits

The `ATTENTION` signal output provides indication of status condition(s). A condition or multiple conditions which will trigger this output are selectable using the MDrive 34ac Hybrid Step • Torque • Speed configuration tool.

The output is galvanically isolated by means of an optocoupler.

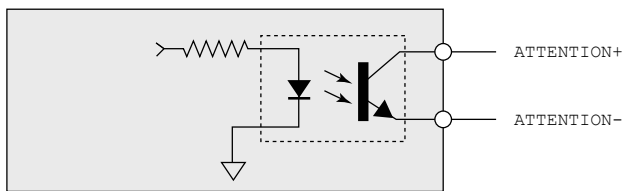

Figure 6.8: ATTENTION signal output

Analog input

The ANALOG_IN is functionally mode-dependent. In Step/direction mode it has no function. In speed control mode the signal on the input will control shaft velocity. In torque mode the signal on the input will control the torque applied to the shaft. The input may be configured to sense one of three input types using the MDrive 34ac Hybrid Step • Torque • Speed Commissioning Utility:

- 0 - 5V
- 0 - 10V
- - 10 to +10V

10 kΩ Potentiometer

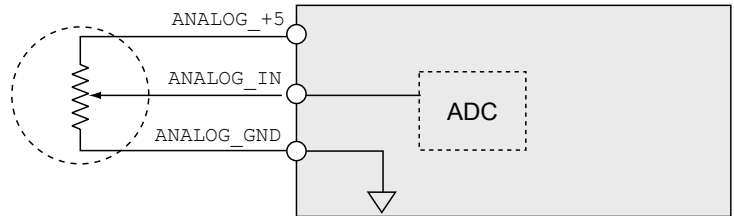

Figure 6.9: ANALOG_IN signal input

Encoder output interface

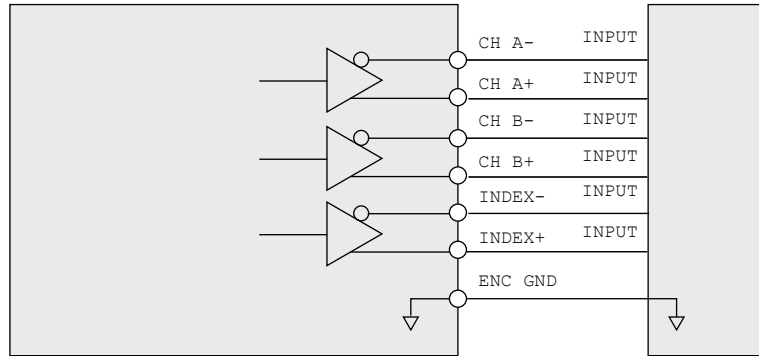

Figure 6.10: Encoder interface.

6.3.4 Connection of the communication interface

Pin assignments

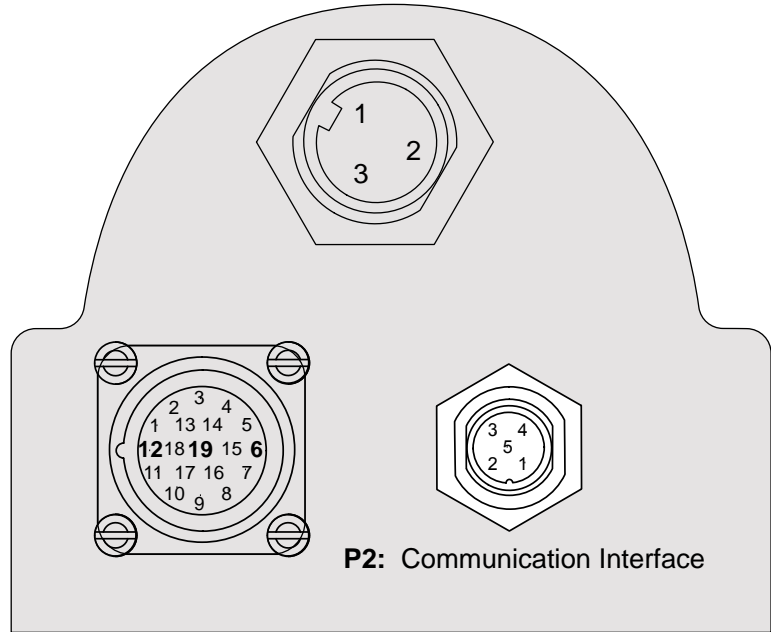

Figure 6.11: Communications interface pin assignments

Pin	Signal	Function
1	TX- OUT	Transmit minus output
2	TX+ OUT	Transmit plus output
3	RX+ IN	Receive plus input
4	RX- IN	Receive minus input
5	COMM GND	Communications ground



A continual connection to the RS422/485 bus is only required if parameters will need to be changed during operation. Once commissioned, the device may be operated solely via the multifunction interface.

For ease of connection and parameterization, an isolated USB to RS422/485 converter is available. See Section 10: Accessories, for details.

Function The drive system is commissioned via the RS422/485 interface and the commissioning software.

In addition, the RS422/485 interface allows you to network the product as a slave in an RS422/485 network.

Connector style 5-pin M12 circular

Recommendation for field attachable 5-pin M12 male connector:

Straight: Lumberg: RKC 5/9 (male)

Right-angle: Lumberg RKCW 5/9 (male)

Wiring/cable specifications

- Shielded cable
- Twisted-pair cables
- Grounding of the shield at both ends

Max cable length ¹⁾	feet (m)	1312 (400)
Minimum conductor cross section	AWG (mm ²)	22 (0.25)
Maximum conductor cross section	AWG (mm ²)	18 (1.0)
Stripping length	inches (mm)	0.25 (6.0)

1) The length depends on the data rate and loading. See EIA485 Standard.

- ▶ Use equipotential bonding conductors.
- ▶ Use pre-assembled cables to reduce the risk of wiring errors.
- ▶ Verify that wiring, cables and connected interfaces meet the PELV requirements.

Single mode full-duplex interface

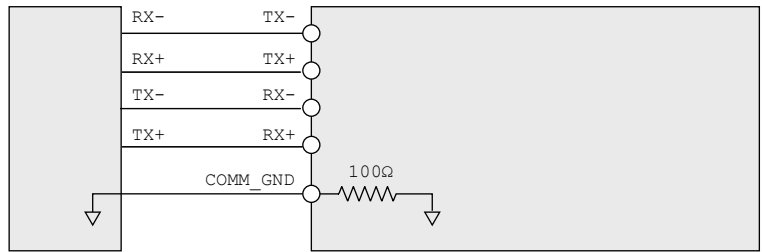

Figure 6.12: Full duplex interface, single mode (RS422).

Single mode half-duplex interface

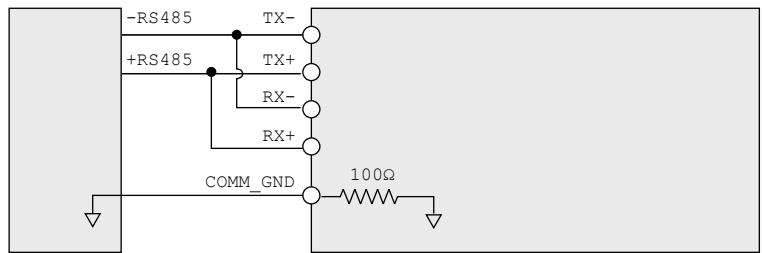

Figure 6.13: Half-duplex interface, single mode (RS-422/485).

Party mode full-duplex interface

Both ends of the entire bus system must be terminated with a terminating resistor. The resistor value is 120Ω connected between the TX+ and TX- and RX+ and RX- lines.

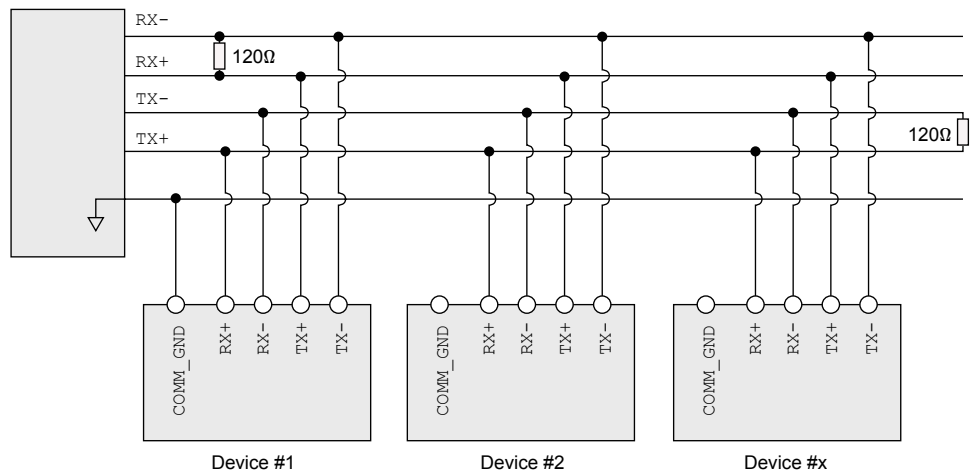

Figure 6.15: Full-duplex interface, party mode (RS422).

6.4 Checking wiring

Check the following:

- ▶ Did you properly install and connect all cables and connectors?
- ▶ Are there any live, exposed cables?
- ▶ Did you properly connect the signal wires?

7 Commissioning

7

▲ WARNING

UNEXPECTED MOVEMENT

Drives may perform unexpected movements because of incorrect wiring, incorrect settings, incorrect data or other errors.

Interference (EMC) may cause unpredictable responses in the system.

- Carefully install the wiring in accordance with the EMC requirements.
- Ensure the `BRIDGE_ENABLE` input is inactive to avoid an unexpected restart of the motor before switching on and configuring the drive system.
- Do NOT operate the drive system with unknown settings or data.
- Perform a comprehensive commissioning test.

Failure to follow these instructions can result in death or serious injury.

▲ WARNING

UNINTENDED BEHAVIOR

The behavior of the drive system is governed by numerous stored data or settings. Unsuitable settings or data may trigger unexpected movements or responses to signals and disable monitoring functions.

- Do NOT operate the drive system with unknown settings or data.
- Verify that the stored data and settings are correct.
- When commissioning, carefully run tests for all operating states and potential fault situations.
- Verify the functions after replacing the product and also after making changes to the settings or data.
- Only start the system if there are no persons or obstructions in the hazardous area.

Failure to follow these instructions can result in death or serious injury.

▲ WARNING**ROTATING PARTS**

Rotating parts may cause injuries and may catch clothing or hair. Loose parts or parts that are unbalanced may be flung.

- Verify correct mounting and installation of all rotating parts.
- Use a cover to help protect against rotating parts.

Failure to follow these instructions can result in death or serious injury.

▲ WARNING**MOTOR WITHOUT BRAKING EFFECT**

If power outage and faults cause the power stage to be switched off, the motor is no longer stopped by the brake and may increase its speed even more until it reaches a mechanical stop.

- Verify the mechanical situation.
- If necessary, use a cushioned mechanical stop or a suitable brake.

Failure to follow these instructions can result in death or serious injury.

▲ WARNING**FALLING PARTS**

The motor may move as a result of the reaction torque; it may tip and fall.

- Mount the motor securely so it will not break loose during strong acceleration.

Failure to follow these instructions can result in death or serious injury.

▲ CAUTION**HOT SURFACES**

Depending on the operation, the surface may heat up to more than 100°C (212°F).

- Do not allow contact with the hot surfaces.
- Do not allow flammable or heat-sensitive parts in the immediate vicinity.
- Consider the measures for heat dissipation described.
- Check the temperature during test runs.

Failure to follow these instructions can result in injury or equipment damage.

7.1 Preparing for commissioning

CAUTION

MULTI-MODE OPERATION

This device will operate differently in each mode of operation. It is critical that all documentation be read completely. A clear understanding of how the device is to be employed be present before attempting to install or commission the device.

Failure to follow these instructions can result in equipment damage.

The following tests are required before commissioning:

- ▶ The device may be commissioned in system or out of system.
- ▶ Only supply voltage V_{DC} and the Service interface connections are required for commissioning.

For commissioning, a PC with the MDrive 34ac Hybrid Step • Torque • Speed Commissioning Utility is required.

7.1.1 Hybrid Configuration Utility manual

The MDrive Hybrid Configuration Utility is REQUIRED to commission the device as the unit is shipped with a configuration application installed.

The desired , step, torque, speed or velocity application MUST be loaded during commissioning for the device to function.

All parameters and functions, as well as procedures for commissioning are documented in the MDrive Hybrid Configuration Utility manual available from the internet at:

<http://motion.schneider-electric.com/>

Page intentionally left blank

8 Operation

8

The chapter “Operation” describes the basic functions of the drive.

8.1 Basics

8.1.1 Overview

Modes of operation

The operational functionality of the MDrive 34ac Hybrid Step • Torque • Speed Pulse direction is impacted by the selected mode of operation. It can operate independently as a pulse/direction input device, a variable torque controller, a variable speed controller or a constant velocity drive.

The “MDrive 34ac Hybrid Step • Torque • Speed” moves the stepper motor in a fashion dictated by the selected mode:

- **Step/direction mode:** In Step/direction mode the device will move the stepper motor as specified by a reference value. The setpoint signal is generated by a position or stepper controller and fed to the I/O interface as a pulse signal. Shaft direction is controlled by a logic state on the direction input of the I/O interface.
- **Torque control mode:** In torque control mode the device will maintain constant torque on the shaft at a value determined by a reference voltage fed to the analog input of the I/O interface. The pulses are generated via an velocity clock generator.
- **Speed control mode:** In speed control mode the device will move the stepper motor at a velocity determined by a reference voltage fed to the analog input of the I/O interface. The pulses are generated via an internal velocity generator.
- **Velocity control mode:** In velocity control mode the device will move the stepper motor at a constant velocity determined by an integer value input via the communication interface. The pulses are generated via an internal velocity generator.

In this chapter the functionality of each mode will be addressed.

8.1.2 Hybrid motion technology (HMT)

Hybrid motion technology is the core control technology that enables the multi-mode functionality of the MDrive 34ac Hybrid Step • Torque • Speed by overcoming many of the limitations inherent in stepper systems. Two major limitations addressed by this technology are:

- Loss of motor synchronization and subsequent stalling.
- Excessive motor heated due to limited current control options

Calibration The purpose of calibration is to bring the rotor and stator into alignment which allows operation of the Hybrid Motion logic. The Hard Stop Tolerant (HST) calibration technique seeks to ensure proper alignment when the rotor is mechanically prohibited from movement by a hard stop or excessive stick/slip.

HST tests for freedom of movement by attempting a 6 full step (10.8 deg) move in the CW direction followed by a 3 full step (5.4 deg) move in the CCW direction. The sequence proceeds as follows.

Pause for CT(Calibration Time) allowing system to settle.

- Perform 6 full step CW move.
- Wait for CT.
- Perform 3 full step CCW move.
- Pause for CT allowing rotor to settle
- Set Calibration complete flag.

If motion is blocked the following occurs:

- If the 1st move can not complete it is abandoned.
- If the 2nd move can not complete it is abandoned then the sequence will be restarted one time.
- If neither move can be completed after 2 times through the sequence an error 109 will be generated, the calibration complete flag will set, and the bridges will be disabled (a locked rotor response).
- To correct, ensure that the motor shaft is free to in both directions. Torque compensation mode may be used for high inertia loads. Calibration current may be increased as well.

Calibration time and distance required when the motor is free to move in both directions.

- The time required typically is 3.12 seconds when CT is 250 mS. This value of CT gives the best compromise between time and proper calibration.
- Motor position will be advanced 3 full steps CW from initial position after calibration is complete. Motor position can be confirmed using the encoder counter C2. The step counter C1 does not count calibration steps

Calibration time and distance when motor is blocked.

- The time will vary significantly based on where in the motion and which motion is blocked. When the motor can not move at all in either direction the failure will typically indicate in 10 seconds.
- The motor position will also vary significantly based on which motion is effected and where within the motion.

- The motor position can be determined using the encoder counter C2. The step counter C1 does not count calibration steps.

The following indicate when calibration is complete.

- On power up, calibration is complete when the sign on message is sent.
- The flag register AF can be polled for the Calibration Complete flag.
- The trip on flag capability (TA to define, TE to enable) can be used also.
- The flags are useful after a manually initiated calibration.

For mechanical systems with a large amount of prevailing torque a secondary calibration step is available, Torque Compensation (CA=0,1).

- Th process measures and compensates for the prevailing torque.
- This typically adds 50 mS to the total calibration time and 1 encoder edge of movement

Loss of synchronization

Synchronized motion in a stepper motor requires that the lead/lag relationship between the rotor and stator be within +/- 2 motor full steps. As this relationship drifts toward the 2 step point the torque available to the load is reduced, with maximum constant torque available at the <= 1 full step point.

Conditions that can cause the stepper motor to lose synchronization and stall are:

Rotor lags stator:

- Acceleration is too rapid to apply enough torque to overcome the inertia of the load.
- Transient load condition at velocity; i.e. load being increased on a conveyor.

Rotor leads stator:

- Deceleration is too rapid to hold the load within the +/- 2 full step range.
- Overhauling load condition where the momentum of the load is greater than the torque supplied to maintain constant velocity.

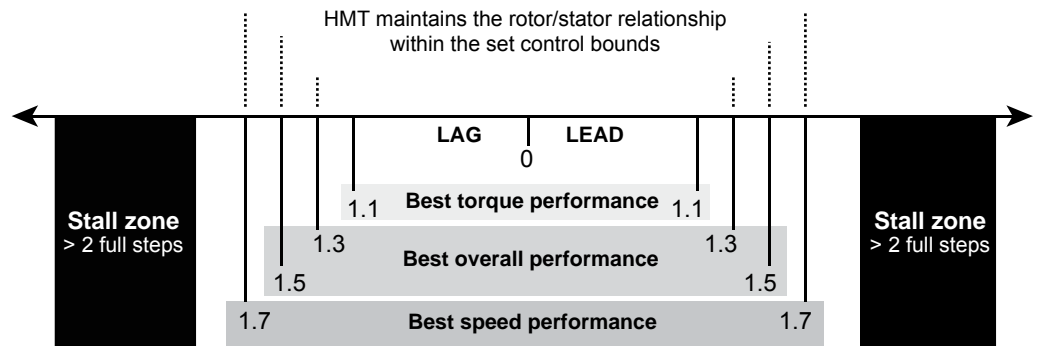

Figure 8.1: Control bounds for hybrid motion technology

HMT uses a high speed feedback loop to tightly maintain the rotor - stator relationship within a specified range, or control bounds.

Variable current control Historically stepper motor drivers operate at two adjustable current levels:

- 1) Running current, the current level in use when the shaft is moving
- 2) Holding or reduction current, the current level in use when the shaft is at rest.

Variable current control uses HMT to accurately measure and track the rotor -stator relationship and apply current as needed, such as during acceleration or deceleration, then reducing the current to the level required to move the load when the axis is at velocity. This can lead to greater power efficiency and cooler running motor.

Position make-up When active, the position make-up function stores the difference between commended pulses and actual motor steps in a register. At the completion of the move the lead or lag pulses will be reinserted into the profile and moved to the commanded position at one of two velocity presets.

8.1.2 Overview of motor phase current

The motor phase current of the drive is influenced by the following factors:

- The setting of the run current.
- The setting of the holding current.
- The setting of the holding current delay time
- Current control defined as fixed or variable.

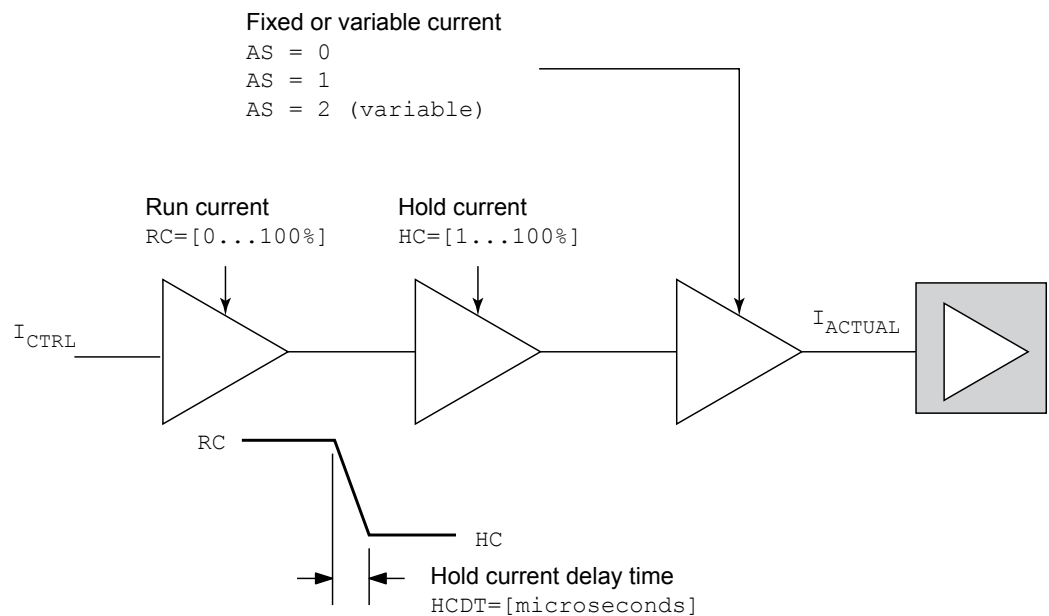

Figure 8.2: Overview of motor phase current

8.2 Functions by mode

Inputs that share common functions across different modes are duplicated within each modes operational description for ease of access.

8.2.1 Pulse/direction input mode

Operation In Pulse/direction input mode the operational functionality of the device will depend on the setting of the HMT mode parameter setting (AS). This parameter will determine the disabled/enabled state of the Hybrid Motion Technology and fixed or variable current mode.

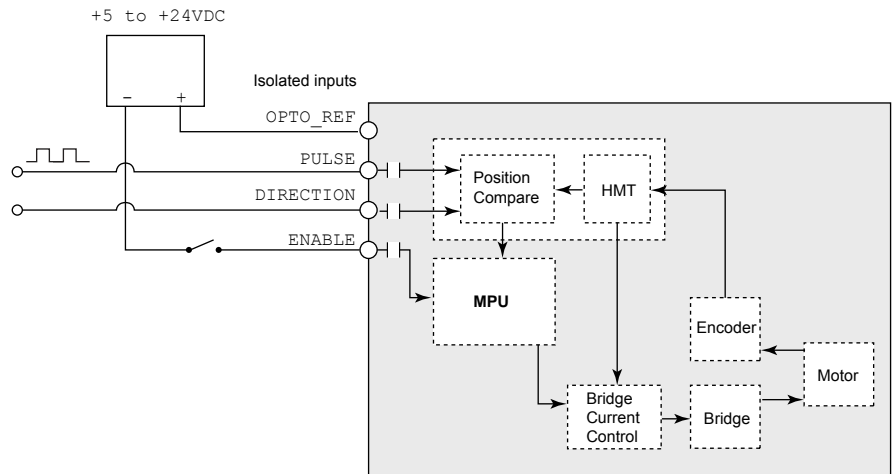

Figure 8.3: Step/direction mode block diagram

Hybrid mode settings

- AS=0 (Bypass mode):** in this mode the HMT circuitry is disabled. The motor steps, speed and positioning respond directly to signals input to the PULSE and DIRECTION inputs. Position monitoring may be accomplished via the encoder outputs as internal lead/lag tracking registers are inactive. The device will be in fixed current mode.
- AS=1 (HMT active):** in this mode the HMT circuitry is enabled and HMT will prevent loss of synchronization. Pulse signals are passed through to the control elements based upon the rotor lead-lag relationship as measured by the encoder. Lost or gained steps are stored in the lead/lag register (LL). These may be accessed and used to make a correctional move, either manually or using position Make-up (MU). The device will be in fixed current mode.
- AS=2 (HMT active):** in AS=2 mode the device will function as in AS=1, the difference being is the device will be in variable current mode.

The signal input PULSE/MOTION and DIRECTION may be used for interfacing the following input clock types.

- Pulse/direction
- A/B (quadrature)
- CW/CCW (clock up/clock down)

Pulse/Direction inputs

The motor angle step with the rising edge of the pulse signal, the direction of rotation is controlled by the DIR signal.

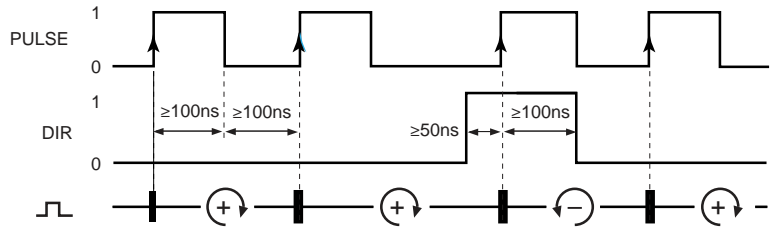

Figure 8.4: Pulse/direction signals and timing

Signal	Signal value	Meaning
PULSE	Rising edge ¹⁾	Angle step
DIRECTION	0/open ¹⁾	Clockwise direction
	1	Counterclockwise operation

1) Factory default setting. PULSE and DIRECTION signals may be inverted using parameters.

A/B (quadrature inputs)

In “A/B” interface mode, A/B encoder signals are supplied as reference values.

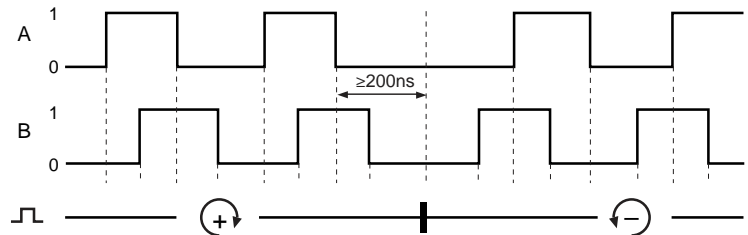

Figure 8.5: A/B (quadrature) encoder signals

CW/CCW interface mode The motor angle step with the rising edge of the pulse signal, the direction of rotation is controlled by the input receiving pulses. This function is also known as clock up/clock down.

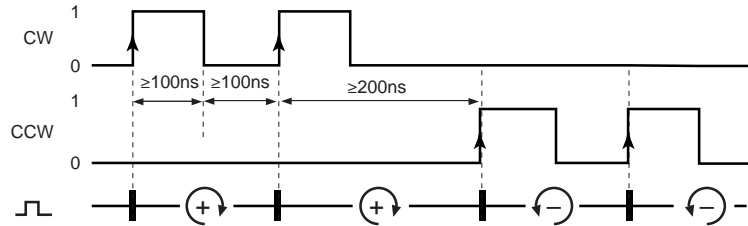

Figure 8.6: CW/CCW (clock up/down) input signals

Input line filtering (FM Filter Motion)

The input filter is used to filter out high frequency electrical noise from the pulse/direction interface. This results in smooth motion and accurate positioning.

Settings via MDrive Hybrid Configuration Utility

The filtering of the inputs is set using the FM (filter motion) parameter. This can be set to 50 ns to 12.9 μs (10 MHz to 38.8 kHz).

Bridge enable input

This input can be used to enable or disable the driver bridge circuitry. Leaving the enable switch open (disconnected, floating) for sinking or sourcing configuration, the driver bridge will be enabled and the step clock pulses will cause the motor to advance. When this input switch is closed in both sinking and sourcing configurations, the driver bridge circuitry will be disabled. Please note that the internal sine/cosine position generator will continue to increment or decrement as long as step clock pluses are being received by the MDrive 34ac Hybrid Step • Torque • Speed.

Settings via MDrive Hybrid Configuration Utility

The active state of the BRIDGE_ENABLE input is set using the Enable Active (EA mnemonic) field on the I/O settings tab of the utility. Input filtering of 0 ... 255 ms may be applied to the input using the Enable Line Filter option (FE).

8.2.2 Torque mode

Operation When in torque mode the device will use the analog input to control the motor torque. The HMT circuitry will maintain the rotor-stator relationship to with control bounds of 1.1 motor full steps. The internal velocity generator will operate at the speed is necessary to maintain constant torque. Variable current control is not available in torque mode as torque is relational to current, with current directly controlled by the analog input.

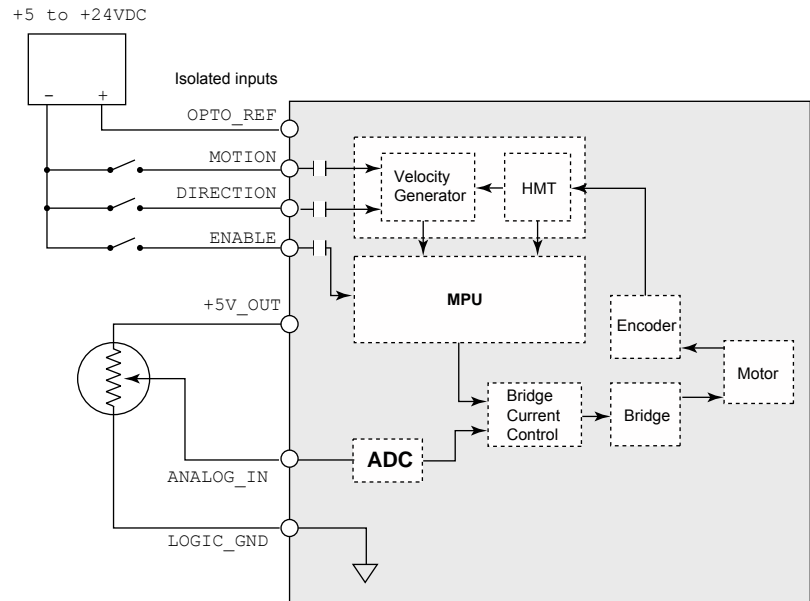

Figure 8.7: Torque mode block diagram showing sinking input interface

In torque control mode the device is controlled using the following inputs:

- ANALOG_IN input to control torque.
- PULSE/MOTION input to enable/disable the internal velocity generator.
- BRIDGE_ENABLE input
- Direction may be controlled one of two ways:
 - Hardware input to the DIRECTION input
 - Center point setting of the ANALOG_IN

Analog input The ANALOG_IN may be interfaced to a 0 ... 5V. 0 ...10V or -10 ... +10V input as selected by parameters.

The voltage, or current, on the input will control the motor output torque from 0% to the max torque setting [TQ%] as set using either the mnemonic or the TQ parameter on the operation sub-tab of the Hybrid settings tab of the utility.

Settings via MDrive Hybrid Configuration Utility

The Analog input has 5 settings:

- **Input Mode (AM):** The input mode sets the input to respond to one of three input types
 - 0 to 5V
 - 0 to 10V
 - -10 to +10V
- **Analog Full Scale (AF):** the input sensing is scaled to a count range of 1 - 1023. The full scale of the input may be set within that range.

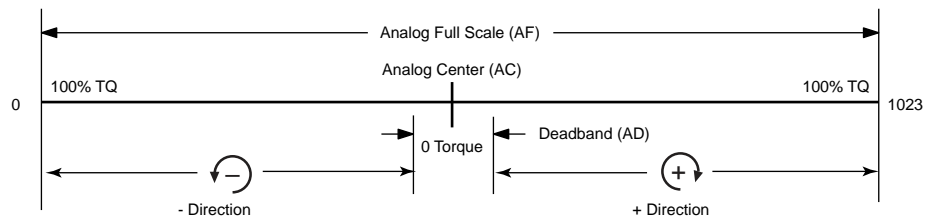

Figure 8.8: Analog settings for torque mode

- **Analog Center Count (AC):** this parameter will set the center point of the input within the 0 to 1023 scale. This will set the 0% torque reference to that value. When crossed the axis will move in the opposite direction.

NOTE: when using the centerpoint to control + and - direction be aware the motor will have 0% torque in the deadband. The load may not change and begin moving until the shaft torque is sufficient to overcome the inertia of the load. If torque is required at directional change use the DIRECTION input to switch between directions.

- **Analog Deadband (AD):** the analog deadband sets the range, in counts, on either side of the Analog Center. In this envelop the device will not respond to the input signal.
- **Analog Filter (AA):** sets the filtering level for the ANALOG_IN. The filtering represents a running average value based upon the filter setting (AA) and the current reading of the input as: $((AA-1)/AA)*\text{current reading} + (1 / AA)$ If AA = 10, then: $((\text{current averaged value} * 9)/10) + (\text{new reading} / 10) = \text{NEW current averaged value}$.

Motion input The PULSE/MOTION input when in torque mode operates as a stop/start switch for the internal velocity generator. It operates independently of the BRIDGE_ENABLE input. placing the input in the stop position will stop motion while maintaining the torque percent referenced by the ANALOG_IN.

Settings via MDrive Hybrid Configuration Utility

The active state of the PULSE/MOTION input is set using Motion Polarity parameter. The input can be active high or low.

The filtering for the input may be set from 1 ... 255 ms using the Motion Debounce parameter.

Bridge enable input This input can be used to enable or disable the driver bridge circuitry. Leaving the enable switch open (disconnected, floating) for sinking or sourcing configuration, the driver bridge will be enabled and the step clock pulses will cause the motor to advance. When this input switch is closed in both sinking and sourcing configurations, the driver bridge circuitry will be disabled. Please note that the internal sine/cosine position generator will continue to increment or decrement as long as step clock pluses are being received by the MDrive 34ac Hybrid Step • Torque • Speed.

Settings via MDrive Hybrid Configuration Utility

The active state of the BRIDGE_ENABLE input is set using the Enable Active (EA mnemonic) field on the I/O settings tab of the utility. Input filtering of 0 ... 255 ms may be applied to the input using the Enable Line Filter option (FE).

8.2.3 Speed control mode

Operation When in speed control mode the device will use the analog input to control the motor speed. The analog input will control the internal velocity generator to move the axis at a velocity between the initial set velocity (VI) and the maximum set velocity (VM).

For this mode additional parameters are available, notably ACCELERATION (A) and DECELERATION (D)

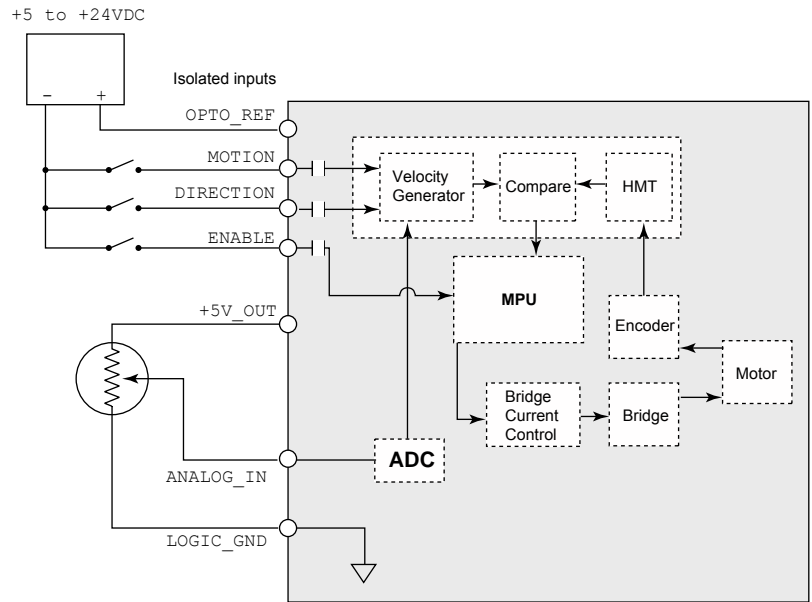

Figure 8.9: Speed control mode block diagram showing sinking input interface

Hybrid mode settings

- **AS=0 (Bypass mode):** in this mode the HMT circuitry is disabled. The motor speed responds directly to signals input to the ANALOG input. Internal lead/lag tracking registers are inactive. The device will be in fixed current mode.
- **AS=1 (HMT active):** in this mode the HMT circuitry is enabled and HMT will prevent loss of synchronization. Pulse signals from the internal velocity generator to the control elements based upon the rotor lead-lag relationship as measured by the encoder. Lost or gained steps are stored in the lead/lag register (LL). If Make-up (MU) is active the device will continually attempt to keep the rotor stator relationship synchronized. The device will be in fixed current mode.
- **AS=2 (HMT active):** in AS=2 mode the device will function as in AS=1, the difference being is the device will be in variable current mode.

In speed control mode the device is controlled using the following inputs:

- ANALOG_IN input to control speed.
- PULSE/MOTION input to enable/disable the internal velocity generator.
- BRIDGE_ENABLE input
- Direction may be controlled one of two ways:
 - Hardware input to the DIRECTION input
 - Center point setting of the ANALOG_IN

Analog input The ANALOG_IN may be interfaced to a 0 ... 5V, 0 ...10V or -10 ... +10V input as selected by parameters.

The voltage, or current, on the input will control the motor output speed from INITIAL VELOCITY (VI) to the MAX_VELOCITY (VM).

Settings via MDrive Hybrid Configuration Utility

The ANALOG input has 5 settings:

- **Input Mode (AM):** The input mode sets the input to respond to one of three input types
 - 0 to 5V
 - 0 to 10V
 - -10 to +10V
- **Analog Full Scale (AF):** the input sensing is scaled to a count range of 1 - 1023. The full scale of the input may be set within that range.

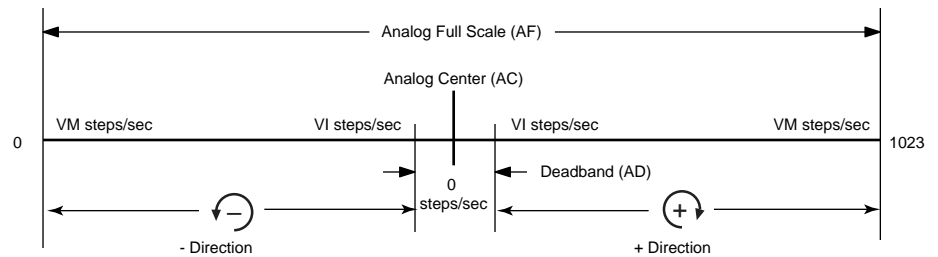

Figure 8.10: Analog settings for speed control mode

- **Analog Center Count (AC):** this parameter will set the center point of the input within the 0 to 1023 scale. This will set the 0% torque reference to that value. When crossed the axis will move in the opposite direction.
- **Analog Deadband (AD):** the analog deadband sets the range, in counts, on either side of the Analog Center. In this envelope the device will not respond to the input signal.
- **Analog Filter (AA):** sets the filtering level for the ANALOG_IN. The filtering represents a running average value based upon the filter setting (AA) and the current reading of the input as: $\left(\frac{AA-1}{AA}\right) \times \text{current reading} + \left(\frac{1}{AA}\right) \times \text{new reading}$. If AA = 10, then: $\left(\frac{9}{10}\right) \times \text{current averaged value} + \left(\frac{1}{10}\right) \times \text{new reading} = \text{NEW current averaged value}$.

Motion input The PULSE/MOTION input when in speed control mode operates as a stop/start switch for the internal velocity generator. It operates independently of the BRIDGE_ENABLE input. placing the input in the stop position will stop motion..

Settings via MDrive Hybrid Configuration Utility

The active state of the PULSE/MOTION input is set using Motion Polarity parameter. The input can be active high or low.

The filtering for the input may be set from 1 ... 255 ms using the Motion Debounce parameter.

Bridge enable input This input can be used to enable or disable the driver bridge circuitry. Leaving the enable switch open (disconnected, floating) for sinking or sourcing configuration, the driver bridge will be enabled and the step clock pulses will cause the motor to advance. When this input switch is closed in both sinking and sourcing configurations, the driver bridge circuitry will be disabled. Please note that the internal sine/cosine position generator will continue to increment or decrement as long as step clock pluses are being received by the MDrive 34ac Hybrid Step • Torque • Speed.

Settings via MDrive Hybrid Configuration Utility

The active state of the BRIDGE_ENABLE input is set using the Enable Active (EA mnemonic) field on the I/O settings tab of the utility. Input filtering of 0 ... 255 ms may be applied to the input using the Enable Line Filter option (FE).

8.2.4 Constant velocity mode

Operation When in constant velocity mode the device will respond SLEW (SL) commands input via the communication interface. The internal velocity generator will then accelerate the axis to the commanded velocity. The MAX_VELOCITY (VM) command does not impact the commanded velocity.'

SLEW commands are given in steps per second. Example:

```
SL ±[VELOCITY] or SL -500000 (Slew CCW @ 500000 steps/sec)
```

A constant velocity move is terminating by commanding an SL 0.

For this mode additional parameters are available, notably ACCELERATION (A) and DECELERATION (D)

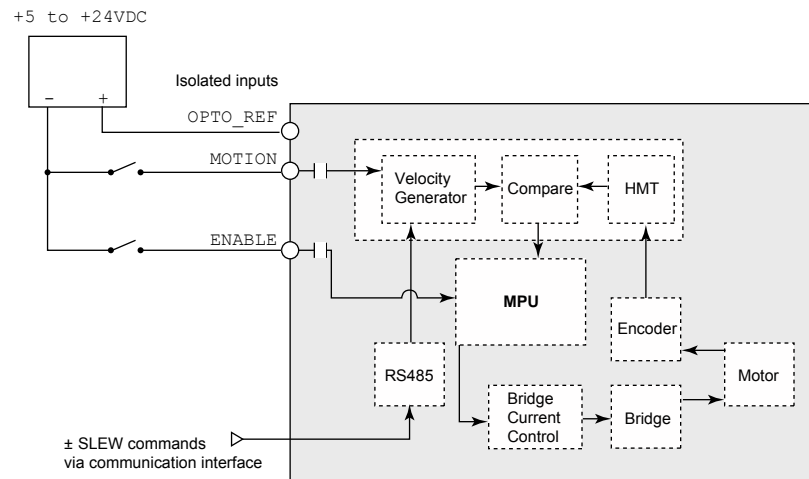

Figure 8.11: Speed control mode block diagram showing sinking input interface

Hybrid mode settings

- **AS=0 (Bypass mode):** in this mode the HMT circuitry is disabled. The motor speed responds directly to SLEW commands entered via RS-422/485 Internal lead/lag tracking registers are inactive. The device will be in fixed current mode.
- **AS=1 (HMT active):** in this mode the HMT circuitry is enabled and HMT will prevent loss of synchronization. Pulse signals from the internal velocity generator to the control elements based upon the rotor lead-lag relationship as measured by the encoder. Lost or gained steps are stored in the lead/lag register (LL). If Make-up (MU) is active the device will continually attempt to keep the rotor stator relationship synchronized at the commanded velocity. The device will be in fixed current mode.
- **AS=2 (HMT active):** in AS=2 mode the device will function as in AS=1, the difference being is the device will be in variable current mode.

In constant velocity mode the device is controlled using the following inputs:

- PULSE/MOTION input to enable/disable the internal velocity generator.
- BRIDGE_ENABLE input
- Direction may be controlled one of two ways:
 - Hardware input to the DIRECTION input
 - Entering the SLEW command as + or - [VELOCITY]

NOTE: In this mode it is generally advisable to leave the DIRECTION input disconnected and control direction via SLEW polarity.

Motion input

The PULSE/MOTION input when in constant velocity mode operates as a stop/start switch for the internal velocity generator. It operates independently of the BRIDGE_ENABLE input. placing the input in the stop position will stop motion, but the output bridge circuitry will remained powered.

Settings via MDrive Hybrid Configuration Utility

The active state of the PULSE/MOTION input is set using Motion Polarity parameter. The input can be active high or low.

The filtering for the input may be set from 1 ... 255 ms using the Motion Debounce parameter.

Bridge enable input

This input can be used to enable or disable the driver bridge circuitry. Leaving the enable switch open (disconnected, floating) for sinking or sourcing configuration, the driver bridge will be enabled and the step clock pulses will cause the motor to advance. When this input switch is closed in both sinking and sourcing configurations, the driver bridge circuitry will be disabled. Please note that the internal sine/cosine position generator will continue to increment or decrement as long as step clock pluses are being received by the MDrive 34ac Hybrid Step • Torque • Speed.

Settings via MDrive Hybrid Configuration Utility

The active state of the BRIDGE_ENABLE input is set using the Enable Active (EA mnemonic) field on the I/O settings tab of the utility. Input filtering of 0 ... 255 ms may be applied to the input using the Enable Line Filter option (FE).

8.3 Attention output

▲ CAUTION

OUTPUT FUNCTION

The attention output is designed for status indication only. It is not to be used for alarm or safety function.

Failure to follow these instructions can result in injury or equipment damage.

The attention output operates independently of mode selection and is used for status indication/action.

This output can be used to relay the status of multiple conditions relative to the Hybrid Motion Technology. These are:

- 1) Error (software) flag
- 2) Locked rotor
- 3) Lead limit reached
- 4) Lag limit reached
- 5) HMT active
- 6) Calibration active
- 7) Over temperature
- 8) Fault (reserved for future use)
- 9) At zero crossing
- 10) Current reduction active
- 11) Make-up in progress
- 12) Calibration fault
- 13) Drive enable false

Signal value	Meaning
1	Condition exists
0	No conditions exist

9 Diagnostics and troubleshooting

9

9.1 Error indication and troubleshooting

9.1.1 Operation state and error indication

Temperature monitoring Sensors in the drive measure the temperature of the power stage.

If the permissible maximum temperature is exceeded, the power stage switches off. Indication can be read by:

- Setting the `ATTENTION_OUT` to activate on over-temperature.
- Reading the error code (71) using a terminal emulator or the MDrive Hybrid Configuration Utility

Stall detection (HMT disabled) Detecting a stall condition may be accomplished by monitoring the encoder index outputs via the multifunction interface.

A stall condition can only exist when HMT is disabled (`AS=0`). HMT will prevent loss of synchronization and subsequent stalls from occurring.

Locked rotor (HMT enabled) A locked rotor indication identifies the condition where the rotor-stator relationship exceeded lead/lag limits (`LD/LG`) and/or locked rotor timeout (`LT`) as specified during parameterization. When this condition occurs the power stage will disable and a locked rotor error will asserted.

A locked rotor condition can only exist when HMT is enabled (`AS=1/AS=2`)

This status may be read using:

- Setting the `ATTENTION_OUT` to activate on locked rotor.
- The HMT status bits
- The error code (81)

9.2 Error codes

Error codes may be read by querying the device via a terminal emulator using:

```
PR ER
```

The response will come in the form of the error code existing.

Error code	Meaning
0	No error condition exists
Data errors	
20	Attempted to set unknown variable/flag
21	Attempted to set to an incorrect value
22	VI set greater than or equal to VM
23	VM set less than or equal to VI
24	Illegal data entered
25	Attempted to write to a read only variable or flag
35	Attempting to print illegal variable or flag
37	Command, variable or flag not available in drive
38	Missing parameter separator
Flash errors	
40	Flash check sum fault
41	Boot data blank
Communication errors	
60	Tried to enter unknown command
61	Trying to set illegal baud rate
System errors	
70	Internal temperature warning
71	Internal over temp fault, disabling drive
72	Tried to save while moving
73	Drive over current
Motion errors	
80	Stall detected
81	Locked rotor
82	Config test done - encoder res mismatch
83	Config test done - encoder dir wrong
84	Config test done - encoder res + dir wrong
85	Config not done - drive not enabled
86	Slew not allowed when calibration is in progress
87	Calibration not allowed while in motion
88	Motion stopped by stop/start switch
89	Calibration fault

10 Accessories and spare parts

10

10.1 Accessories

Source commissioning software The latest version of the commissioning software is available for download from the internet:

<http://motion.schneider-electric.com>

Communications converter

Description	Part number
USB to RS422/485	MD-CC401-001

Prototype development cables

Description	Part number	
AC Power	Straight	MD-CS200-000
	Right-angle	MD-CS201-000
I/O	Straight	MD-CS100-000
	Right-angle	MD-CS101-000

Page intentionally left blank

11 Service, maintenance and disposal

11

▲ CAUTION

DAMAGE TO SYSTEM COMPONENTS AND LOSS OF CONTROL

Interruptions of the negative connection of the controller supply voltage can cause excessively high voltages at the signal connections.

- Do not interrupt the negative connection between the power supply unit and load with a fuse or switch.
- Verify correct connection before switching on.
- Do not connect the controller supply voltage or change its wiring while the is supply voltage present..

Failure to follow these instructions can result in injury or equipment damage.

▲ CAUTION

RISK OF INJURY WHEN REMOVING CIRCUIT BOARD PLUGS

- When removing them note that the connectors must be unlocked.
 - Supply voltage VDC: unlock by removing locking screws
 - Multifunction interface: unlock with locking tabs
- Always hold the plug to remove it (not the cable).

Failure to follow these instructions can result in injury or equipment damage.



The product may only be repaired by a certified customer service center. No warranty or liability is accepted for repairs made by unauthorized persons.

11.1 Service address



If you cannot resolve an error yourself please contact your sales office. Have the following details available:

- Nameplate (type, identification number, serial number, DOM, ...)
- Type of error (such as error number)
- Previous and concomitant circumstances
- Your own assumptions concerning the cause of the error

Also include this information if you return the product for inspection or repair. Note that units being returned for inspection or repair must be accompanied by a Return Material Authorization (RMA).

Technical or applications support is available via the internet at:

<http://motion.schneider-electric.com>

11.2 Maintenance

Check the product for pollution or damage at regular intervals, depending on the way you use it.

11.3 Replacing units

▲ WARNING

UNINTENDED BEHAVIOR

The behavior of the drive system is governed by numerous stored data or settings. Unsuitable settings or data may trigger unexpected movements or responses to signals and disable monitoring functions.

- Do NOT operate the drive system with unknown settings or data.
- Verify that the stored data and settings are correct.
- When commissioning, carefully run tests for all operating states and potential fault situations.
- Verify the functions after replacing the product and also after making changes to the settings or data.
- Only start the system if there are no persons or obstructions in the hazardous area.

Failure to follow these instructions can result in death or serious injury.

Only start the system if there are no persons or obstructions in the hazardous area.

- ▶ Switch off all supply voltages. Verify that no voltages are present (safety instructions).
- ▶ Label all connections and uninstall the product.
- ▶ Note the identification number and the serial number shown on the product nameplate for later identification.
- ▶ Install the new product as per chapter 6 “Installation”
- ▶ Commission the product as per chapter 7 “Commissioning”.

11.4 Shipping, storage, disposal

Removal Removal procedure:

- ▶ Switch off the power supply.
- ▶ Disconnect the power supply.
- ▶ Pull out all plugs.
- ▶ Remove the product from the system.

Shipping The product must be protected against shocks during transportation. If possible, use the original packaging for shipping.

Storage The product may only be stored in spaces where the specified permissible ambient conditions for room temperature and humidity are met. Protect the product from dust and dirt.

Disposal The product consists of various materials that can be recycled and must be disposed of separately. Dispose of the product in accordance with local regulations.

Page intentionally blank

12 Glossary

12

12.1 Units and conversion tables

The value in the specified unit (left column) is calculated for the desired unit (top row) with the formula (in the field).

Example: conversion of 5 meters [m] to yards [yd]
 $5 \text{ m} / 0.9144 = 5.468 \text{ yd}$

12.1.1 Length

	in	ft	yd	m	cm	mm
in	—	/ 12	/ 36	* 0.0254	* 2.54	* 25.4
ft	* 12	—	/ 3	* 0.30479	* 30.479	* 304.79
yd	* 36	* 3	—	* 0.9144	* 91.44	* 914.4
m	/ 0.0254	/ 0.30479	/ 0.9144	—	* 100	* 1000
cm	/ 2.54	/ 30.479	/ 91.44	/ 100	—	* 10
mm	/ 25.4	/ 304.79	/ 914.4	/ 1000	/ 10	—

12.1.2 Mass

	lb	oz	slug	kg	g
lb	—	* 16	* 0.03108095	* 0.4535924	* 453.5924
oz	/ 16	—	* 1.942559×10^{-3}	* 0.02834952	* 28.34952
slug	/ 0.03108095	* 1.942559×10^{-3}	—	* 14.5939	* 14593.9
kg	/ 0.453592370	/ 0.02834952	/ 14.5939	—	* 1000
g	/ 453.592370	/ 28.34952	/ 14593.9	/ 1000	—

12.1.3 Force

	lb	oz	p	dyne	N
lb	—	* 16	* 453.55358	* 444822.2	* 4.448222
oz	/ 16	—	* 28.349524	* 27801	* 0.27801
p	/ 453.55358	/ 28.349524	—	* 980.7	* 9.807×10^{-3}
dyne	/ 444822.2	/ 27801	/ 980.7	—	/ 100×10^3
N	/ 4.448222	/ 0.27801	/ 9.807×10^{-3}	* 100×10^3	—

12.1.4 Power

	HP	W
HP	—	* 745.72218
W	/ 745.72218	—

12.1.5 Rotation

	min ⁻¹ (RPM)	rad/s	deg./s
min ⁻¹ (RPM)	—	* $\pi / 30$	* 6
rad/s	* $30 / \pi$	—	* 57.295
deg./s	/ 6	/ 57.295	—

12.1.6 Torque

	lb-in	lb-ft	oz-in	Nm	kp-m	kp-cm	dyne-cm
lb-in	—	/ 12	* 16	* 0.112985	* 0.011521	* 1.1521	* 1.129×10^6
lb-ft	* 12	—	* 192	* 1.355822	* 0.138255	* 13.8255	* 13.558×10^6
oz-in	/ 16	/ 192	—	* 7.0616×10^{-3}	* 720.07×10^{-6}	* 72.007×10^{-3}	* 70615.5
Nm	/ 0.112985	/ 1.355822	/ 7.0616×10^{-3}	—	* 0.101972	* 10.1972	* 10×10^6
kp-m	/ 0.011521	/ 0.138255	/ 720.07×10^{-6}	/ 0.101972	—	* 100	* 98.066×10^6
kp-cm	/ 1.1521	/ 13.8255	/ 72.007×10^{-3}	/ 10.1972	/ 100	—	* 0.9806×10^6
dyne-cm	/ 1.129×10^6	/ 13.558×10^6	/ 70615.5	/ 10×10^6	/ 98.066×10^6	/ 0.9806×10^6	—

12.1.7 Moment of inertia

	lb-in ²	lb-ft ²	kg-m ²	kg-cm ²	kp-cm-s ²	oz-in ²
lb-in ²	—	/ 144	/ 3417.16	/ 0.341716	/ 335.109	* 16
lb-ft ²	* 144	—	* 0.04214	* 421.4	* 0.429711	* 2304
kg-m ²	* 3417.16	/ 0.04214	—	* 10×10^3	* 10.1972	* 54674
kg-cm ²	* 0.341716	/ 421.4	/ 10×10^3	—	/ 980.665	* 5.46
kp-cm-s ²	* 335.109	/ 0.429711	/ 10.1972	* 980.665	—	* 5361.74
oz-in ²	/ 16	/ 2304	/ 54674	/ 5.46	/ 5361.74	—

12.1.8 Temperature

	°F	°C	K
°F	—	(°F - 32) * 5/9	(°F - 32) * 5/9 + 273.15
°C	°C * 9/5 + 32	—	°C + 273.15
K	(K - 273.15) * 9/5 + 32	K - 273.15	—

12.1.9 Conductor cross section

AWG	1	2	3	4	5	6	7	8	9	10	11	12	13
mm²	42.4	33.6	26.7	21.2	16.8	13.3	10.5	8.4	6.6	5.3	4.2	3.3	2.6
AWG	14	15	16	17	18	19	20	21	22	23	24	25	26
mm²	2.1	1.7	1.3	1.0	0.82	0.65	0.52	0.41	0.33	0.26	0.20	0.16	0.13

12.2 Terms and Abbreviations

AC Alternating current

Acceleration The time rate of change of velocity with respect to a fixed reference frame. The commanded step rate is started at a base velocity and accelerated at a slew velocity at a defined and controlled rate or rate of changes.

ASCII American Standard Code for Information Interchange. Standard for coding of characters.

Back Electro-Motive Force (Back EMF) Also known as regeneration current, the reversed bias generated by rotation of the magnetic field across a stator's windings. Sometimes referred to as counter EMF.

CAN (Controller Area Network), standardized open fieldbus as per ISO 11898, allows drives and other devices from different manufacturers to communicate.

CANopen CANopen is a CAN-based higher layer protocol. It was developed as a standardized embedded network with highly flexible configuration capabilities. CANopen was designed motion oriented machine control networks, such as handling systems. It is used in many various fields, such as medical equipment, off-road vehicles, maritime electronics, public transportation, building automation, etc

Closed Loop System In motion control, this term describes a system wherein a velocity or position (or both) sensor is used to generate signals for comparison to desired parameters. For cases where loads are not predictable, the closed loop feedback from an external encoder to the controller may be used for stall detection, position maintenance or position verification.

Daisy Chain This term is used to describe the linking of several devices in sequence, such that a single signal stream flows through one device and on to another

<i>DC</i>	Direct current
<i>Deadband</i>	A range of input signals for which there is no system response.
<i>Default value</i>	Factory setting.
<i>Detent Torque</i>	The periodic torque ripple resulting from the tendency of the magnetic rotor and stator poles to align themselves to positions of minimal reluctance. The measurement is taken with all phases de-energized.
<i>Direction of rotation</i>	Rotation of the motor shaft in a clockwise or counterclockwise direction of rotation. Clockwise rotation is when the motor shaft rotates clockwise as you look at the end of the protruding motor shaft.
<i>DOM</i>	The Date of manufacturing on the nameplate of the device is shown in the format DD.MM.YY, e.g. 31.12.06 (December 31, 2006).
<i>Duty Cycle</i>	For a repetitive cycle, the ratio of on time to total cycle time.
<i>EMC</i>	Electromagnetic compatibility
<i>Encoder</i>	Sensor for detection of the angular position of a rotating component. The motor encoder shows the angular position of the rotor.
<i>Error class</i>	Classification of errors into groups. The different error classes allow for specific responses to faults, e.g. by severity.
<i>Fatal error</i>	In the case of fatal error, the drive is not longer able to control the motor, so that an immediate switch-off of the drive is necessary.
<i>Fault</i>	Operating state of the drive caused as a result of a discrepancy between a detected (computed, measured or signaled) value or condition and the specified or theoretically correct value or condition.
<i>Fault reset</i>	A function used to restore the drive to an operational state after a detected fault is cleared by removing the cause of the fault so that the fault is no longer active (transition from state "Fault" to state "Operation Enable").
<i>Forcing</i>	Forcing switching states of inputs/outputs. Forcing switching states of inputs/outputs.
<i>Full Duplex</i>	The transmission of data in two directions simultaneously. For example, a telephone is a full-duplex device because both parties can talk at the same time.

<i>Ground Loop</i>	A ground loop is any part of the DC return path (ground) that has more than one possible path between any two points.
<i>Half Duplex</i>	A ground loop is any part of the DC return path (ground) that has more than one possible path between any two points.
<i>Half Step</i>	This term means that the motor shaft will move a distance of 0.9 degree (400 steps per shaft revolution) instead of moving 1.8 degree per digital pulse.
<i>Hybrid Motion Technology™ (HMT)</i>	A motor control technology representing a new paradigm in brushless motor control. By bridging the gap between stepper and servo performance, HMT offers system integrators a third choice in motion system design.
<i>Hybrid Motors</i>	Hybrid stepper motors feature the best characteristics of PM and VR motors. Hybrid steppers are best suited for industrial applications because of high static and run torque, a standard low step angle of 1.8°, and the ability to Microstep. Hybrid stepper motors offer the ability to precisely position a load without using a closed-loop feedback device such as an encoder.
<i>Holding Torque</i>	The maximum torque or force that can be externally applied to a stopped, energized motor without causing the rotor to rotate continuously. This is also called “static torque”.
<i>I/O</i>	Inputs/outputs
<i>Inc</i>	Increments
<i>Index pulse</i>	Signal of an encoder to reference the rotor position in the motor. The encoder returns one index pulse per revolution.
<i>Inertia</i>	A measure of an object’s resistance to a change in velocity. The larger an object’s inertia, the greater the torque required to accelerate or decelerate it. Inertia is a function of an object’s mass and shape. For the most efficient operation, the system-coupling ratio should be selected so that the reflected inertia of the load is equal to or no greater than 10 times the rotor inertia of the stepper motor.
<i>Inertia (Reflected)</i>	Inertia as seen by the stepper motor when driving through a speed change, reducer or gear train.
<i>Lag</i>	The amount (in full motor steps) that the rotor lags the stator. Lag conditions are caused by loading on the motor shaft, as during transient loading or rapid acceleration.

<i>Lead</i>	The amount (in full motor steps) that the rotor leads the stator. Lead conditions are caused by an overhauling load, as during periods of rapid deceleration.
<i>Limit switch</i>	Switch that signals overtravel of the permissible range of travel.
<i>Load</i>	Any external resistance (static or dynamic) to motion that is applied to the motor.
<i>Locked rotor</i>	When the lag/lead limit is reached, a timer starts a countdown that is determined by the user. The locked rotor will assert itself by triggering a flag and, depending on the selected mode, by disabling the output bridge.
<i>Loss of synchronization</i>	In traditional stepper systems, when the lead/lag relationship of the rotor and stator reaches two full motor steps, the alignment of the magnetic fields is broken and the motor will stall in a freewheeling state. Hybrid Motion Technology eliminates this.
<i>Microstepping</i>	A control electronic technique that proportions the current in a stepper motor's windings to provide additional intermediate positions between poles. Produces smooth rotation over a wide range and high positional resolution. Typically, step resolutions range from 400 to 51,200 steps per shaft revolution.
<i>Motor phase current</i>	The available torque of a stepper motor is determined by the motor phase current. The higher the motor phase current the higher the torque.
<i>Multidrop</i>	A communications configuration in which several devices share the same transmission line, although generally only one may transmit at a time. This configuration usually uses some kind of polling mechanism to address each connected device with a unique address code.
<i>NEMA</i>	The acronym for the National Electrical Manufacturer's Association, an organization that sets standards for motors and other industrial electrical equipment.
<i>Node guarding</i>	Monitoring of the connection with the slave at an interface for cyclic data traffic.
<i>Open Loop System</i>	An open loop motion control system is where no external sensors are used to provide position or velocity feedback signals, such as encoder feedback of position.

<i>Opto-Isolated</i>	A method of sending a signal from one piece of equipment to another without the usual requirement of common ground potentials. The signal is transmitted optically with a light source (usually a Light Emitting Diode) and a light sensor (usually a photo-sensitive transistor). These optical components provide electrical isolation.
<i>Parameter</i>	Device data and values that can be set by the user.
<i>Persistent</i>	Indicates whether the value of the parameter remains in the memory after the device is switched off.
<i>PLC</i>	Programmable logic controller
<i>Position lead/lag</i>	The HMT circuitry continually tracks the position lead or lag error, and may use it to correct position.
<i>Position make-up</i>	When active, the position make-up can correct for position errors occurring due to transient loads. The lost steps may be interleaved with incoming steps, or reinserted into the profile at the end of a move.
<i>Power stage</i>	The power stage controls the motor. The power stage generates currents for controlling the motor on the basis of the positioning signals from the controller.
<i>Pull-In Torque</i>	This is the maximum torque the stepper motor can develop when instantaneously started at that speed.
<i>Pull-Out Torque</i>	This is the maximum torque that the stepper can develop once an acceleration profile has been used to “ramp” it to the target speed.
<i>Quick Stop</i>	Function used to enable fast deceleration of the motor via a command or in the event of a malfunction.
<i>Resolution</i>	The smallest positioning increment that can be achieved.
<i>Resonance</i>	The frequency that a stepper motor system may begin to oscillate. Primary resonance frequency occurs at about one revolution per second. This oscillation will cause a loss of effective torque and may result in loss of synchronism. The designer should consider reducing or shifting the resonance frequency by utilizing half step or micro-step techniques or work outside the primary resonance frequency.
<i>Rotor</i>	The moving part of the motor, consisting of the shaft and the magnets. These magnets are similar to the field winding of a brush type DC motor

<i>. Rotor Inertia</i>	The rotational inertia of the rotor and shaft.
<i>RS-422/485</i>	Fieldbus interface as per EIA-485 which enables serial data transmission with multiple devices.
<i>Sinking Current</i>	Refers to the current flowing into the output of the chip. This means that a device connected between the positive supply and the chip output will be switched on when the output is low.
<i>Slew</i>	The position of a move profile where the motor is operating at a constant velocity
<i>Sourcing Current</i>	Refers to the current flowing out of the output of the chip. This means that a device connected between the chip output and the negative supply will be switched on when the output is high.
<i>Stall detection</i>	Stall detection monitors whether the index pulse is always correctly triggered at the same angle position of the motor shaft.
<i>Stator</i>	The stationary part of the motor. Specifically, it is the iron core with the wire winding in it that is pressed into the shell of the frame. The winding pattern determines the voltage constant of the motor.
<i>Torque ramp</i>	Deceleration of the motor with the maximum possible deceleration, which is only limited by the maximum permissible current. The higher the permissible braking current, the stronger the deceleration. Because energy is recovered up depending on the coupled load, the voltage may increase to excessively high values. In this case the maximum permissible current must be reduced.
<i>Variable current control</i>	When active, variable current control will control the motor current as such to maintain the torque and speed on the load to what is required by the profile. This leads to reduced motor heating and greater system efficiency.
<i>Warning</i>	If not used within the context of safety instructions, a warning alerts to a potential problem detected by a monitoring function. A warning is not a fault and does not cause a transition of the operating state. Warnings belong to error class 0.
<i>Watchdog</i>	Unit that monitors cyclic basic functions in the product. Power stage and outputs are switched off in the event of faults.
<i>Zero crossing</i>	The point in a stepper motor where one phase is at 100% current and the other is at 0% current.

WARRANTY

TWENTY-FOUR (24) MONTH LIMITED WARRANTY

Schneider Electric Motion USA warrants only to the purchaser of the Product from Schneider Electric Motion USA (the "Customer") that the product purchased from Schneider Electric Motion USA (the "Product") will be free from defects in materials and workmanship under the normal use and service for which the Product was designed for a period of 24 months from the date of purchase of the Product by the Customer. Customer's exclusive remedy under this Limited Warranty shall be the repair or replacement, at Company's sole option, of the Product, or any part of the Product, determined by Schneider Electric Motion USA to be defective. In order to exercise its warranty rights, Customer must notify Company in accordance with the instructions described under the heading "Obtaining Warranty Service".

NOTE: MDrive Motion Control electronics are not removable from the motor in the field. The entire unit must be returned to the factory for repair.

This Limited Warranty does not extend to any Product damaged by reason of alteration, accident, abuse, neglect or misuse or improper or inadequate handling; improper or inadequate wiring utilized or installed in connection with the Product; installation, operation or use of the Product not made in strict accordance with the specifications and written instructions provided by IMS; use of the Product for any purpose other than those for which it was designed; ordinary wear and tear; disasters or Acts of God; unauthorized attachments, alterations or modifications to the Product; the misuse or failure of any item or equipment connected to the Product not supplied by Schneider Electric Motion USA; improper maintenance or repair of the Product; or any other reason or event not caused by Schneider Electric Motion USA.

Schneider Electric Motion USA HEREBY DISCLAIMS ALL OTHER WARRANTIES, WHETHER WRITTEN OR ORAL, EXPRESS OR IMPLIED BY LAW OR OTHERWISE, INCLUDING WITHOUT LIMITATION, ANY WARRANTIES OF MERCHANTABILITY OR FITNESS FOR ANY PARTICULAR PURPOSE. CUSTOMER'S SOLE REMEDY FOR ANY DEFECTIVE PRODUCT WILL BE AS STATED ABOVE, AND IN NO EVENT WILL IMS BE LIABLE FOR INCIDENTAL, CONSEQUENTIAL, SPECIAL OR INDIRECT DAMAGES IN CONNECTION WITH THE PRODUCT.

This Limited Warranty shall be void if the Customer fails to comply with all of the terms set forth in this Limited Warranty. This Limited Warranty is the sole warranty offered by Schneider Electric Motion USA with respect to the Product. Schneider Electric Motion USA does not assume any other liability in connection with the sale of the Product. No representative of Schneider Electric Motion USA is authorized to extend this Limited Warranty or to change it in any manner whatsoever. No warranty applies to any party other than the original Customer.

Schneider Electric Motion USA and its directors, officers, employees, subsidiaries and affiliates shall not be liable for any damages arising from any loss of equipment, loss or distortion of data, loss of time, loss or destruction of software or other property, loss of production or profits, overhead costs, claims of third parties, labor or materials, penalties or liquidated damages or punitive damages, whatsoever, whether based upon breach of warranty, breach of contract, negligence, strict liability or any other legal theory, or other losses or expenses incurred by the Customer or any third party.

OBTAINING WARRANTY SERVICE

If the Product was purchased from an Schneider Electric Motion USA Distributor, please contact that Distributor to obtain a Returned Material Authorization (RMA). If the Product was purchased directly from Schneider Electric Motion USA, please contact Customer Service at info@imshome.com or 860-295-6102 (Eastern Time Zone).

Customer shall prepay shipping charges for Products returned to Schneider Electric Motion USA for warranty service and Schneider Electric Motion USA shall pay for return of Products to Customer by ground transportation. However, Customer shall pay all shipping charges, duties and taxes for Products returned to Schneider Electric Motion USA from outside the United States.

Schneider Electric Motion USA

370 North Main Street, P.O. Box 457

Marlborough, CT 06447 - U.S.A.

Tel. +00 (1) 860 295-6102 - Fax +00 (1) 860 295-6107

e-mail: info@imshome.com

<http://motion.schneider-electric.com>

© Schneider Electric Motion USA All Rights Reserved.
*Product Disclaimer and most recent product information at
motion.schneider-electric.com.*

V.1.00, 07, 2012

